

DATA SHEET



T 5862 EN

Types 3260/3274 and 3260/3374 Electric Control Valves

Types 3260/3372, 3260-1 and 3260-7 Pneumatic Control Valves

Type 3260 Globe Valve



Application

Globe valves for use in industrial applications as well as heating, ventilation and air-conditioning systems

DN 65 to 150 · PN 16 · Temperatures up to 150 °C

Special features

- Type 3260 designed as a globe valve
- Connection between valve and actuator: form-fit connection
- Type 3260 Globe Valve in special version for oils, up to DN 125

Versions

Electric control valves with Type 3260 Globe Valve		
Type 3260/3374	PN 16	DN 65 to 150
Type 3260/3274 ¹⁾	PN 16	DN 65 to 150
Pneumatic control valves with Type 3260 Globe Valve		
Type 3260/3372	PN 16	DN 65 to 150
Type 3260-1	PN 16	DN 65 to 80
Type 3260-7 ²⁾	PN 16	DN 65 to 80

¹⁾ Types 3274-21/-22 Electric Actuators with fail-safe action

²⁾ Pneumatic actuator suitable for integrated positioner attachment

Also available:

- Type 3260 Three-way Valve ► T 5861

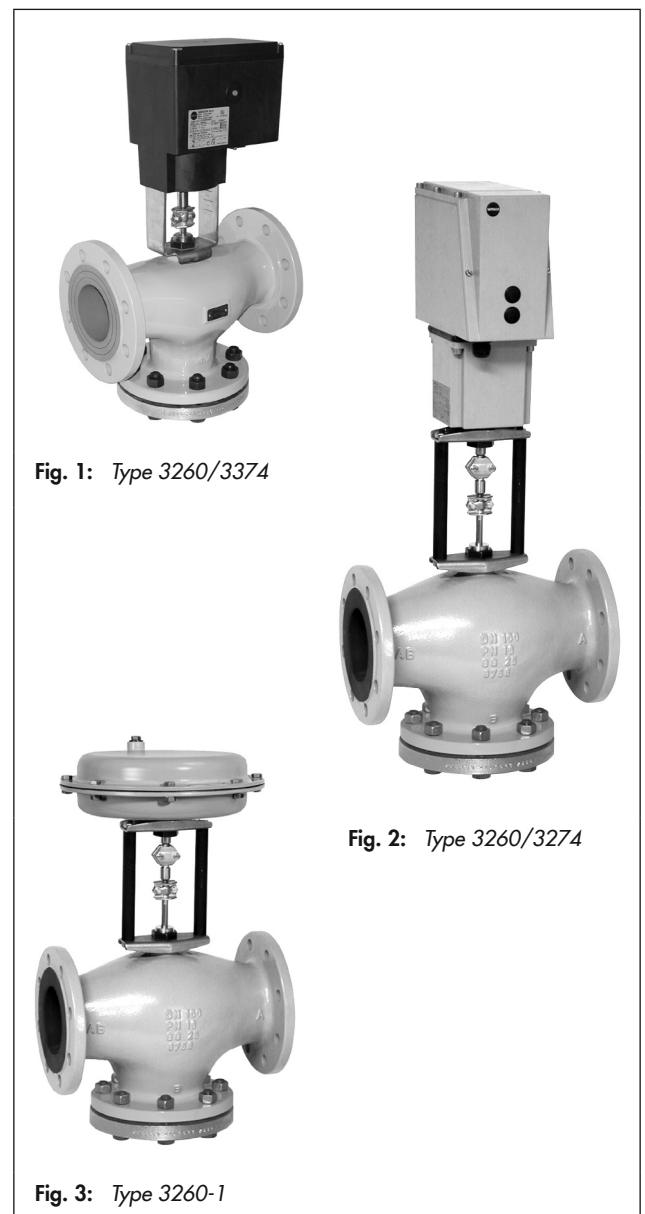

Fig. 1: Type 3260/3374

Fig. 2: Type 3260/3274

Fig. 3: Type 3260-1

Principle of operation (Fig. 4)

The process medium flows through the valve in the direction indicated by the arrow in the flow-to-open direction. The cross-sectional area of flow between the seat (2) and plug (3) is determined by the position of the valve stem. The plug is moved by changing the control signal applied to the actuator. The plug stem (6) is designed to form-fit the actuator stem (8.1) and is sealed by an EPDM or FKM seal.

Fail-safe position

For globe valves mounted to an actuator with fail-safe action, the control valve has two different positions which become effective upon power supply failure:

Actuator stem extends

- The globe valve closes upon power supply failure

Actuator stem retracts

- The globe valve opens upon power supply failure

Electric actuators

The Type 3374 Electric Actuator as well the Type 3274 Electrohydraulic Actuator can be controlled either using a three-step signal or, in the version with positioner, with signals from 0/4 to 20 mA or from 0/2 to 10 V. Various electrical accessories can be optionally installed.

Types 3274-21 and 3274-22 Actuators are able to perform a fail-safe action. Refer to Table 4.

Refer to the data sheets for more details on the electric actuators:

▶ **T 8331:** Type 3374 Electric Actuator

▶ **T 8340:** Type 3274 Electrohydraulic Actuator

Pneumatic actuators

The Types 3271 and 3277 Pneumatic Actuators as well as the Type 3372 Electropneumatic Actuator work with various control signals (see Table 5.2).

All actuators are available for fail-safe action "actuator stem extends (FA)" or "actuator stem retracts (FE)".

The Type 3277 Pneumatic Actuator is suitable for integral positioner attachment. Various optional accessories can be mounted onto the actuator.

Types 3271 and 3277 Actuator are also available with hand-wheel.

Refer to the data sheets for more details on the pneumatic actuators:

▶ **T 8310-1:** Types 3271 and 3277 Pneumatic Actuators

Installation of the control valve

The control valves can be mounted in any position. However, the electric actuators must not be suspended downwards.

Make sure that the ambient temperature at the point of installation does not exceed or fall below the permissible temperature limits specified for each actuator.

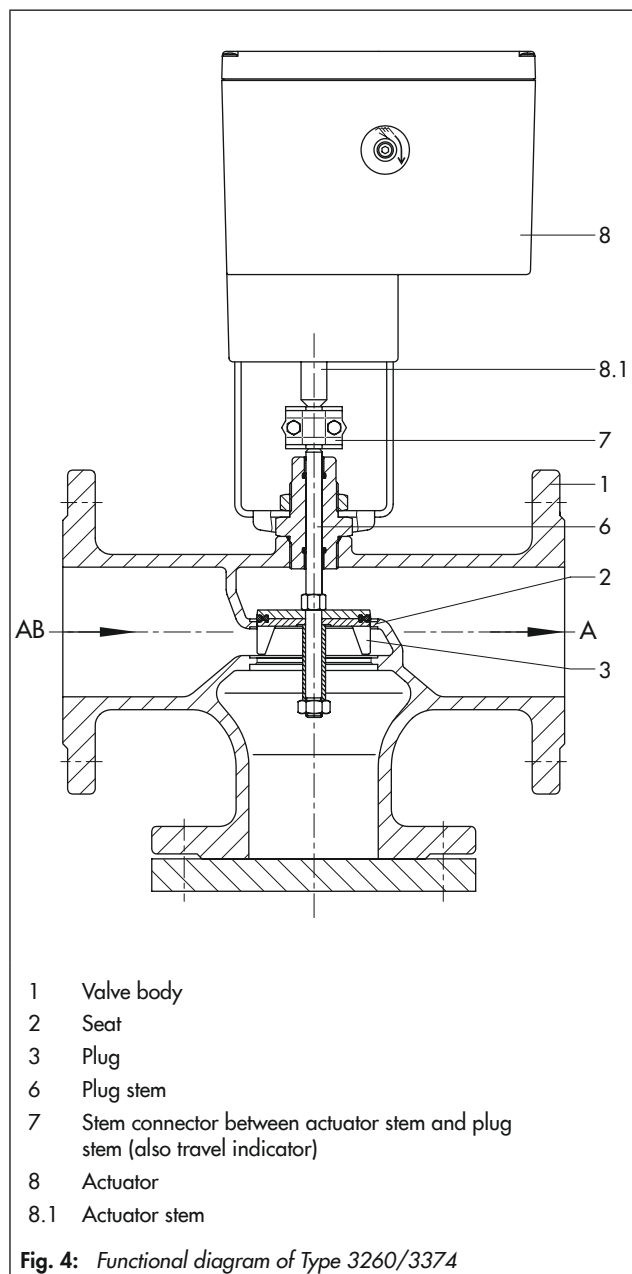

Fig. 4: Functional diagram of Type 3260/3374

Ordering text

Type ... Control Valve with Type 3260 designed as globe valve:

3260/3274-..., 3260/3374-...

3260/3372, 3260-1, 3260-7

- Valve size: DN ...
- Kvs coefficient: ...
- Special version for oils: yes, no

Further specifications on the electric actuator

- Control: three-step signal, positioner
- Supply voltage ...
- Electric additional equipment ...

Further specifications on the pneumatic actuator

- Effective area: ...
- Bench range: ...
- Fail-safe action: stem extends (FA), stem retracts (FE)

Table 1: Technical data

Type 3260 Globe Valve						
Valve size	DN	65	80	100	125	150
Pressure rating	PN	16				
Permissible temperature range	°C	5 to 150				
Plug seal		Soft seal				
Leakage class according to IEC 60534-4		Class IV (≤ 0.01 % of K_{VS} coefficient)				
Rated travel	mm	15		30		
Conformity ¹⁾		CE EAC				

¹⁾ Field of applications are the control of Group II fluids according to Pressure Equipment Directive 2014/68/EU. However, it does not include steam and neutral vapors. The permissible temperature range applies.

Table 2: Materials · Material numbers according to DIN EN

Type 3260 Globe Valve	
Valve body and seat	Cast iron EN-GJL-250 (GG-25)
Plug	Brass · CC754 · CW617
Plug stem	Stainless steel 1.4305
Seat-plug seal	EPDM (standard) · FKM (special version up to DN 125)
Stem seal	EPDM seal ring
Special version for oils (up to DN 125)	FKM seal
Rod-type yoke	See actuator

Table 3: Valve sizes, K_{VS} coefficients and seat diameters

Type 3260 Globe Valve						
Valve size	DN	65	80	100	125	150
K_{VS} coefficient		60	80	160	250	320
Seat \varnothing	mm	70	70	100	130	130
Rated travel	mm	15	15	30	30	30

Table 4: Possible combinations

Type 3260 Globe Valve/actuator								
Type	Fail-safe action: actuator stem		Details in	Valve size DN				
	Extends	Retracts		65	80	100	125	150
Electric actuators								
3374-11	–	–	▶ T 8331	•	•		–	
3374-10	–	–		•	•	•	•	•
3274-21 ¹⁾	•	–	▶ T 8340	•	•	•	•	•
3274-22 ¹⁾	–	•		•	•	•	•	•
Pneumatic actuators								
3372	•	•	▶ EB 8313	•	•	•	•	•
3271 ¹⁾	•	•	▶ T 8310-1	•	•	–	–	–
3277 ¹⁾	•	•		•	•	–	–	–

¹⁾ Type 3260 Globe Valve in combination with these actuators with rod-type yoke:
 DN 65 to 80: order no. 1890-8696
 DN 100 to 150: order no. 1400-8822

Table 5: Permissible differential pressures (all pressures stated in bar)

The specified differential pressure may be restricted by the pressure-temperature diagram.

Table 5.1: Type 3260/... Electric Control Valves

Type ... Actuator	3374-11	3374-10	3274-21/-22
K_{VS} coefficients	Δp when $p_2 = 0$ bar		
60	4.0	4.0	4.0
80	4.0	4.0	4.0
160	–	2.8	1.9
250	–	1.7	1.1
320	–	1.7	1.1

Table 5.2: Type 3260/... Pneumatic Control Valves

Type ... Actuator	3372				3271 and 3277			
Actuator area ⁴⁾ cm ²	120	120 ²⁾	350 ²⁾	350 ³⁾	175v2	175v2	350	350
Bench range ¹⁾ min. bar	1.4	2.1	0.8	0.9	0.6	1.3	0.4	0.6
max. bar	2.3	3.3	1.3	1.65	3.0	2.9	2.0	3.0
Maximum supply pressure bar	4.0	5.0	2.3	2.5	3.7	4.3	2.5	3.7
K_{VS} coefficients	Δp when $p_2 = 0$ bar							
60	3.8	4.0	–	–	2.1	4.0	3.0	4.0
80	3.8	4.0	–	–	2.1	4.0	3.0	4.0
160	–	–	3.1	3.1	–	–	–	–
250	–	–	1.8	1.8	–	–	–	–
320	–	–	1.8	1.8	–	–	–	–

¹⁾ Other bench ranges only on request

²⁾ Actuator stem extends

³⁾ Actuator stem retracts

⁴⁾ v2 is added to the actuator area (e.g. 175v2 cm²) to indicate that Type 3271 and Type 3277 Actuators have a full diaphragm

Table 6: Dimensions and weights**Table 6.1: Type 3260 Globe Valve**

Valve size DN	65	80	100	125	150
Overall length L1 mm	290	310	350	400	480
Overall length L2 mm	159	171	181	233	246
Height H mm	71	71	112	112	112
Height H1 mm (Type 3372, 350 cm ³)	–	–	382	382	382
Height H2 mm	265	265	306	306	306
Weight kg (approx.)	24	28	44	59	76

Table 6.2: Electric actuators

Type	3374	3274-21/-22
Weight kg (approx.)	3.2	12

Table 6.3: Pneumatic actuators

Type	3372		3271		3277	
Actuator area ¹⁾ cm ²	120	350	175v2	350	175v2	350
Height H' mm	–	–	78	80	78	80
Height H7 mm	–	–	–	–	–	–
Height H3 ²⁾ mm	110	110	110	110	110	110
Diaphragm ØD mm	168	280	215	280	215	280
Supply air port a	G ¼	G ¼	G ¼	G ¾	G ¼	G ¾
Weight kg (approx.)	3.7	15	6	8	10	12

¹⁾ v2 is added to the actuator area (e.g. 175v2 cm²) to indicate that Type 3271 and Type 3277 Actuators have a full diaphragm

²⁾ Minimum clearance required to remove the actuator

Electric control valves

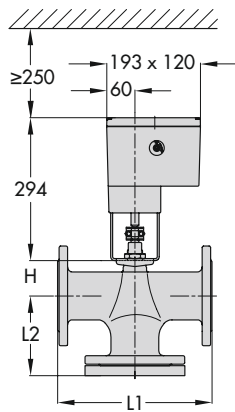

Type 3260/3374: DN 65 to 150

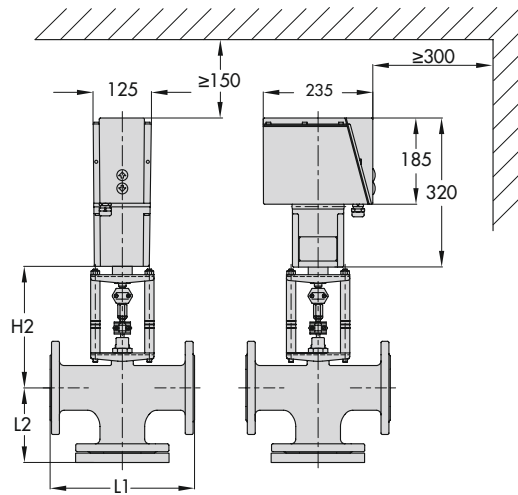

Type 3260/3274: DN 65 to 150

Pneumatic control valves

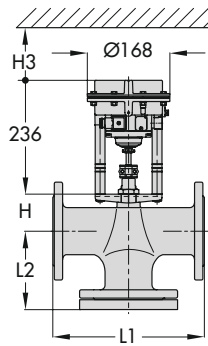

Type 3260/3372:
DN 65 to 80

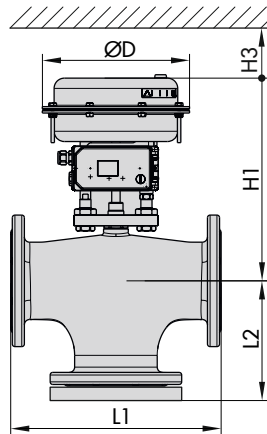

Type 3260/3372:
DN 100 to 150

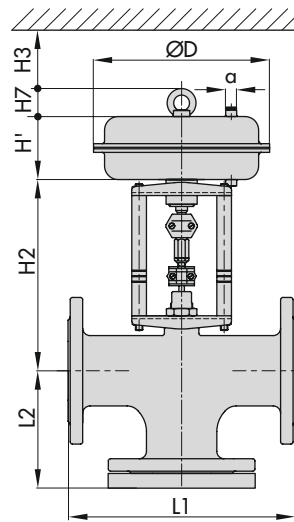

Type 3260-1: DN 65 to 80

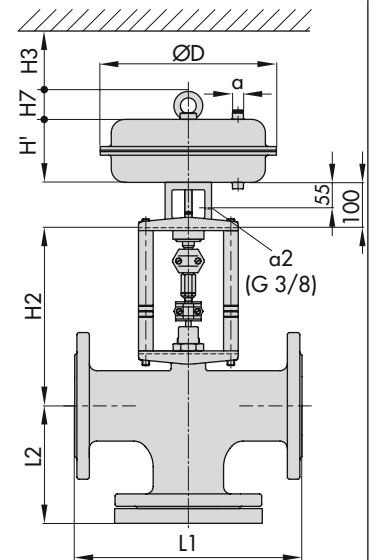

Type 3260-7: DN 65 to 80

