

TROVIS 5757-3 Electric Actuator with Process Controller



for domestic hot water heating



Translation of original instructions

Configuration Manual

KH 5757 EN

Firmware version 2.20

Edition June 2016



Notes on this configuration manual

The documentation for TROVIS 5757-3 Electric Actuator with Process Controller is divided into two parts:

- Mounting and Operating Instructions ► EB 5757
- Configuration Manual KH 5757

This Configuration Manual KH 5757 is intended for qualified personnel with experience in control engineering. All the ready-configured systems are described.

It is assumed that users are familiar with the operation of the device and the TROVIS-VIEW configuration software. If necessary, refer to the associated mounting and operating instructions:

- EB 5757 for the mounting, start up, and operation of the electric actuator with process controller
- EB 6661 for the operation of the TROVIS-VIEW configuration software



The mounting and operating instructions for all supplied devices are included in the delivery. The latest versions of the documents are available on our website at www.samson.de > Product documentation. You can enter the document number or type number in the [Find:] field to look for a document.

Definition of signal words

DANGER

Hazardous situations which, if not avoided, will result in death or serious injury

WARNING

Hazardous situations which, if not avoided, could result in death or serious injury

NOTICE

Property damage message or malfunction

Note

Additional information

Tip

Recommended action

1	General	4
2	Functions and parameters	5
2.1	DHW heating in instantaneous heating system	5
2.1.1	DHW tapping recognition with a flow switch.....	6
2.1.2	Tapping detection using the water flow sensor	7
2.2	Set point changeover.....	7
2.3	Maintaining the heat exchanger at a constant temperature	8
2.4	Excessive temperature protection	9
2.5	Frost protection	9
2.6	Control parameters	10
2.7	External demand processing	10
2.8	Function of switching output	11
2.9	Direction of action.....	12
3	Functions of memory pen	13
3.1	Command mode	13
3.2	Data logging	13
4	Additional readings and functions in the TROVIS-VIEW software	14
4.1	Manual level in TROVIS-VIEW	14
4.2	Operating information	15
4.3	Operating states	15
4.4	Functions	16
4.5	Status messages	16
4.6	Statistics	17
5	Configuration list and customer settings	18
5.1	Customer setting	20

1 General

The functions and parameters are changed in the TROVIS-VIEW software. To transfer settings from the software to the electric actuator or vice versa, they must be connected. See

▶ EB 6661.

WARNING

The software in online mode has a direct influence on the connected device, and, as a result, on the valve. To avoid personal injury or property damage, plant operators and operating personnel must prevent hazards that could be caused in the control valve by the process medium, the operating pressure, the signal pressure or by moving parts by taking appropriate precautions. They must observe all hazard statements, warning and caution notes in the referenced documents.

Accessories for communication:

The TROVIS-VIEW software for revision 2 of the TROVIS 5757-3 Electric Actuator with Process Controller is required. The TROVIS-VIEW software can be downloaded free of charge from our website (▶ www.samson.de at Services > Software > TROVIS-VIEW). The software can also be supplied on a CD-ROM. Further details can be found in Data Sheet ▶ T 6661.

2 Functions and parameters

2.1 DHW heating in instantaneous heating system

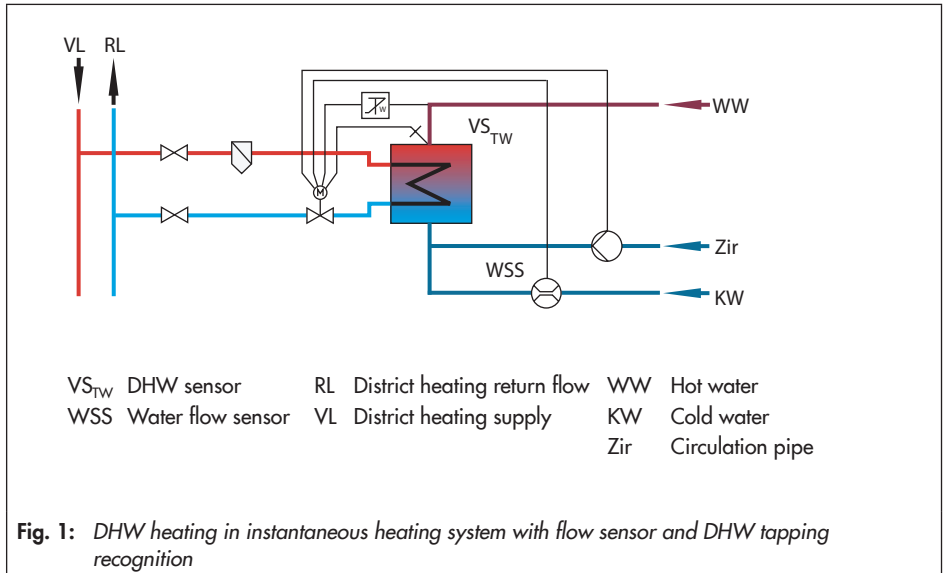

The DHW temperature is controlled to the set point temperature in DHW heating in instantaneous heating systems:

- ➔ If the DHW temperature falls below the set point, the actuator opens the valve (pulses) to increase the DHW temperature.
- ➔ If the DHW temperature exceeds the set point, the actuator closes the valve (pulses) to reduce the DHW temperature.

Functions	WE	Configuration
F01: DHW tapping recognition	1	F01 - 0
Parameters	WE	Value range
P01: Set point W1	60 °C	0 to 100 °C
P02: Set point W2	70 °C	0 to 100 °C

Operation with a DHW sensor

A Pt 1000 temperature sensor (e.g. Type 5207-0060, ideally combined with a sensor pocket to provide the best positioning of the sensor at the heat exchanger) measures the DHW temperature at the heat exchanger. The measured temperature is compared with the set point and the valve is moved accordingly to achieve this temperature (see above).

Operation with a current input

As an alternative to a flow sensor, the input of the current flow temperature can be also be implemented by the current input (0 to 20 mA or 4 to 20 mA). The input signal is based on the measuring range (Xmin to Xmax). The measured DHW temperature is compared with the set point and the valve is moved accordingly to achieve this temperature (see above).

NOTICE

The function to maintain the water temperature at a constant temperature (see section 2.3) cannot be used when the current input is active.

Functions	WE	Configuration
F05: Current input	0	F05 - 1
F06: Function of current input	0	F06 - 0
F07: Measuring range of current input	0	F07 - 0: 0 to 20 mA F07 - 1: 4 to 20 mA

Parameters	WE	Value range
P03: Lower measuring range value Xmin	0 °C	-50 to 90 °C
P04: Upper measuring range value Xmax	100 °C	10 to 150 °C

2.1.1 DHW tapping recognition with a flow switch

The flow switch is used to indicate when DHW tapping is starts and finishes. A closed contact causes the pump to start running (the DHW temperature control at the DHW sensor is active). An open contact causes the valve to close and the pump to be switched off.

Functions	WE	Configuration
F01: DHW tapping recognition	1	F01 - 1
F02: Flow rate sensor	1	F02 - 0

2.1.2 Tapping detection using the water flow sensor

In contrast to the DHW tapping recognition with a flow switch, the extent of tapping is indicated as well as when the DHW tapping starts and finishes.

By activating the optimizing function **Adaptation**, the device adapts itself to changing network conditions without having to change the control parameters (see section 2.6). The optimizing function can only be activated when a water flow sensor is used.

NOTICE

Hot water being tapped is also detected when the maximum flow rate of the water flow sensor is exceeded.

Functions	WE	Configuration
F05: Current input	1	F01 - 1
F06: Function of current input	1	F02 - 1
F07: Measuring range of current input	1	F07 - 1

2.2 Set point changeover

The device can use two different set points, W1 and W2, for control, e.g. hot water temperature in normal used and for thermal disinfection. The set points changeover is implemented by the binary input (BI1):

- BI1 open: W1 is the set point
- BI1 closed: W2 is the set point

It is only possible to change between set points W1 and W2 when the DHW temperature is measured with a Pt 1000 resistance sensor (F05 - 0).

NOTICE

*When the binary input BI1 is used, the current input cannot be used. It also not possible to deactivate **the function to maintain the heat exchanger at a constant temperature** (see section 2.3) when the binary input is used for set point switchover.*

Functions	WE	Configuration
F05: Current input	0	F05 - 0
F08: Function of binary input	0	F08 - 1

2.3 Maintaining the heat exchanger at a constant temperature

When the **DHW tapping recognition** is active, the actuator controls the hot water to the set point temperature only when hot water is demanded. To guarantee that the temperature reaches the set point W1 quickly when hot water is demanded again, the heat exchanger is prevented from cooling down by the function **to maintain the heat exchanger at a constant temperature**: the hot water is kept at a temperature reduced by the *set-back difference*.

Depending on the configuration, the reduced set point applies after hot water has been tapped until the next demand or while the heating period to maintain heat exchanger at constant temperature (P12) is active.

NOTICE

Upon power supply failure, an active function is canceled. After the power supply is reconnected, hot water must be tapped to reactivate the function.

Functions	WE	Configuration
F01: DHW tapping recognition	1	F01 - 1
F09: Maintain heat exchanger at constant temperature	0	F09 - 0: Time adjustable (P12) F09 - 1: Continuous

Parameters	WE	Value range
P11: Set-back difference	8 K	0 to 30 K
P12: Heating period to maintain heat exchanger at constant temperature	24.0 h	0 to 25.5 h

Influence of the binary input B11

If the binary input B11 is not required for set point switchover, it is used to deactivate the function to maintain the heat exchanger at a constant temperature.

- B11 open: function **to maintain heat exchanger at a constant temperature** according to configuration of F09.
 - B11 closed: function inactive
- When the binary input B11 is closed, an active function to maintain the heat exchanger at a constant temperature is immediately terminated, even when the *Heating period to maintain heat exchanger at constant temperature* has not yet elapsed.

NOTICE

When the binary input is active, the current input cannot be used.

Functions	WE	Configuration
F05: Current input	0	F05 - 0
F08: Function of binary input	0	F08 - 0

2.4 Excessive temperature protection

The actuator closes the valve when the flow temperature at the flow sensor exceeds the upper limit (GWH).

When F10 - 0 is configured, **no** monitoring of the flow temperature for violation of the upper limit takes place.

Functions	WE	Configuration
F10: Upper limit (GWH)	0	F10 - 1

Parameters	WE	Value range
P05: Upper limit (GWH)	95 °C	0 to 100 °C

2.5 Frost protection

When the function is active, the flow temperature is monitored for violation of the lower limit. When the temperature falls below the *lower limit (GWL)*, the actuator opens the valve (pulses) until the temperature exceeds the lower limit plus hysteresis.

When F11 - 0 is configured, **no** monitoring of the flow temperature for violation of the lower limit takes place.

Functions	WE	Configuration
F11: Lower limit (GWL)	0	F11 - 1

Parameters	WE	Value range
P06: Lower limit (GWL)	5 °C	0 to 20 °C

2.6 Control parameters

Parameters	WE	Value range
P07: Proportional-action coefficient KP	0.8	0.1 to 50
P08: Reset time Tn	15 s	0 to 999 s
P09: Derivative-action time Tv	0 s	0 to 999 s
P10: Actuator transit time Ty	25 s	0 to 240 s

The actuator transit time T_y *actuator transit time for valve travel* (P10) reflects the time that the valve needs to move through the range from 0 to 100 % without stopping. The default setting is 25 s.

NOTICE

The default setting is based on the rated travel of 6 mm. The actual transit time can be determined by the "Start transit time measurement" parameter. See section 4.4.

2.7 External demand processing

The device can process an external demand for heat depending on the configuration. A measuring range (Xmin to Xmax) is assigned to the current signal (0 to 20 mA or 4 to 20 mA, set point). The external hot water set point has priority over the internal set point.

NOTICE

Only a Pt 1000 sensor can be used to measure the hot water temperature when the function for an external demand is active.

Functions	WE	Configuration
F05: Current input	0	F05 - 1
F06: Function of current input	0	F06 - 1
F07: Measuring range of current input	0	F07 - 0: 0 to 20 mA F07 - 1: 4 to 20 mA

Parameters	WE	Value range
P03: Lower measuring range value Xmin	0 °C	-50 to 90 °C
P04: Upper measuring range value Xmax	100 °C	10 to 150 °C

2.8 Function of switching output

NOTICE

The switching output function is available for electric actuators with firmware 2.x and higher.

The switching output can be configured as either a pump output (circulation pump for the DHW circuit or heating circuit), a fault alarm output or an output to report when hot water is tapped.

- **Passive function:** The switching output is inactive.
- **Function of the fault alarm:** The switching output is active when a fault has occurred.
- **Function of the circulation pump (DHW):** The switching output is active while hot water is being tapped, when the function to maintain the hot water at a constant temperature or the frost protection function is active.
- **Function of the circulation pump (heating):** The switching output is active after a demand for heat (valve position > 0 %).
- **Function of the tapping:** The switching output is active while hot water is being tapped.
- **Function of the circulation pump (heating) reversed:** The switching output is switched off when the actuator stem reaches the top end position.

Functions	WE	Configuration
F16: Function of switching output	1	F16 - 1: Not active F16 - 2: Fault alarm F16 - 3: Circulation pump (DHW) F16 - 4: Circulation pump (heating) F16 - 5: Tapping F16 - 6: Circulation pump (heating) reversed

2.9 Direction of action

Increasing/increasing (F04 - 0)

- Actual value < Set point: Actuator stem retracts
- Actual value > Set point: Actuator stem extends

Increasing/decreasing (F04 - 1)

- Actual value < Set point: Actuator stem extends
- Actual value > Set point: Actuator stem retracts

Actuator stem extended

- With globe valves: Valve CLOSED
- With three-way mixing valves: Port A → AB open, B → AB closed (see Fig. 2)
- With three-way diverting valves: Port AB → A closed, AB → B open

Actuator stem retracted

- With globe valves: Valve OPEN
- With three-way mixing valves: Port A → AB closed, B → AB open (see Fig. 2)
- With three-way diverting valves: Port AB → A open, AB → B closed

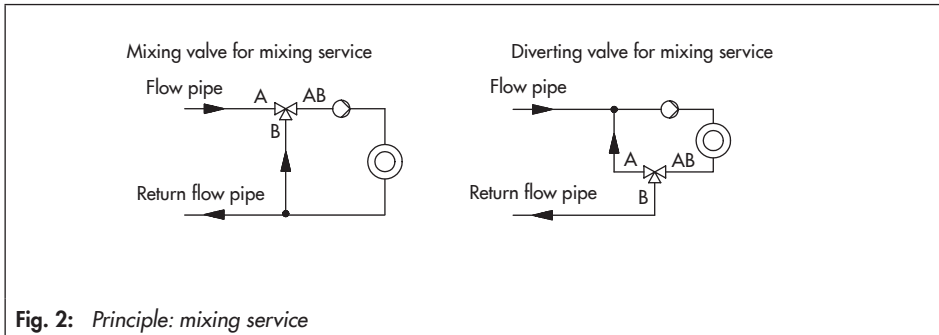

Fig. 2: Principle: mixing service

Functions	WE	Configuration
F04: Direction of action	0	F04 - 0: >> (increasing/increasing) F04 - 1: << (increasing/decreasing)

3 Functions of memory pen

The memory pen can be ordered (order no. 1400-9753). Refer to ► EB 6661 for more details.

3.1 Command mode

A memory pen (order no. 1400-9753) can be configured in TROVIS-VIEW to be a command pen. The command pen allows the actuator stem to be moved to the open and closed positions.

NOTICE

The action of retracting/extending the actuator stem on inserting the command pen has absolute priority. The input signal is overridden.

→ The configuration of the memory pen is explained in ► EB 6661.

3.2 Data logging

NOTICE

The data logging function is available for electric actuators with firmware 2.x and higher.

The memory pen allows the following data to be saved:

- Pt 1000 input
- Flow rate
- Current input
- Actuator stem position
- Positioning value
- Z component
- P component
- I component
- D component
- Error during operation
- Tapping

- Control
 - Maintain temperature constant
 - Frost protection
 - Switching output
 - Torque switch: actuator stem retracted
 - Torque switch: actuator stem extended
 - Adaptation active
 - Adaptation A1 guided
 - Adaptation changed
 - Manual potentiometer
 - Temperature inside device
- Start/stop data logging (► EB 6661)

4 Additional readings and functions in the TROVIS-VIEW software

4.1 Manual level in TROVIS-VIEW

The actuator can be switched to the manual mode using the TROVIS-VIEW software.

The following actions are possible in the manual level:

- Retract actuator stem
- Extend the actuator stem
- Move actuator stem to standardized positioning value
First enter the required positioning value in relation to the input variable range (standardized positioning value).

The electric actuator leaves the manual operation mode as soon as you exit the manual level or the online mode in TROVIS-VIEW.

4.2 Operating information

In online mode the current data measured by the sensors and the active set point are listed in the [Operating values] folder.

Name	Value	Unit	Comment
Measured values			
Input 1	24.2	°C	Actual value
Flow rate	2.7	l/min	Actual value
Input 2	OFF		Actual value
Outputs			
Source of set point	Set point W1		
Calculated actuator travel	100.0	%	
Limit contact			
Actuator stem retracts	ON		
Actuator stem extends	OFF		
Switching output			
State	OFF		
Control			
Control			
Adaptation			

4.3 Operating states

Name	Value	Comment
Operating states		
No error exists		
Functions		
No function active		

4.4 Functions

The screenshot shows the TROVIS-VIEW software interface. The left sidebar shows a tree view with 'TROVIS 5757-3 Electric Actuator with Pr' expanded to 'Service' > 'Functions'. The main window displays a list of functions:

Name	Value	Unit
Manual level		
Functions		
Trigger reset		
Load default settings in actuator		
Start zero calibration		
Start transit time measurement		

4.5 Status messages

The screenshot shows the TROVIS-VIEW software interface with the 'Status messages' menu selected. The main window displays a list of status messages:

Name	Value	Unit	Comment
Actuator			
Firmware version	2.13		
Serial number	16896		
Device information	5757, 2.13		
Manufacturing parameter	10.01.2012 16:35:59		
Operation			
Operating hours	222	h	
Operating hours at excess temperature	0	h	
Temperature inside device	33	°C	
Highest temperature inside device	46	°C	
Lowest temperature inside device	18	°C	
Actuator travels			
Motor running time	0	h	
Attempts	12814		
Changes of direction	754		
Valve strokes			
Travel cycles	71		
LEDs			
Yellow	ON		Actuator is switch
Red	OFF		

4.6 Statistics

The screenshot shows the TROVIS-VIEW software interface. The left sidebar contains a tree view with the following structure:

- TROVIS 5757-3 Electric Actuator with Pr
 - Settings
 - Operating values
 - Service
 - Operating states
 - Functions
 - Status messages
 - Statistics

The main window displays the 'Statistics' section for the 'Service' category. The data is presented in a table with columns for Name, Value, and Comment. The table is organized into several expandable sections:

Name	Value	Comment
Power supply activated	54	
Program interruptions	0	
Limit contact error	1	
EEPROM error	0	
Counter: alarms		
Signal failure at temperature input	3	
Signal failure at current input	0	
Flow rate exceeds measuring range	204	
Upper limit value GWH exceeded	0	
Binary signals counters		
Binary input ON	0	
Switching output ON	38	
Counter: memory pen		
Command: retract stem	0	
Command: extend stem	0	
Data read	4	
Data written	3	
Data logged	0	
Functions counter		
Configuration changed	45	
Parameters changed	78	
Manual level activated	4	
Zero calibration started	0	
Reset triggered	0	
Default settings loaded	1	
Transit time measurement started	0	

5 Configuration list and customer settings

Function block list

The function blocks have the following listed functions.

F = Function block WE = Default setting

F	Function	WE	Meaning
01	DHW tapping recognition	1	0: Continuous control 1: Flow rate sensor active
02	Flow rate sensor	1	0: Flow switch 1: Water flow sensor
03	Adaptation	1	0: Not active 1: Active (with water flow sensor)
04	Direction of action	0	0: >> (increasing/increasing) 1: << (increasing/decreasing)
05	Current input	0	0: Not active (binary input) 1: Active
06	Function of current input	0	0: Actual value 1: Set point
07	Measuring range of current input	0	0: 0 to 20 mA 1: 4 to 20 mA
08	Function of binary input	0	0: Termination of maintaining heat exchanger at constant temperature 1: Switchover between internal set points
09	Maintain heat exchanger at constant temperature	0	0: Time adjustable 1: Continuous
10	Upper limit (GWH)	0	0: No limitation 1: Exceeding GWH causes switch-off
11	Lower limit (GWL)	0	0: No frost protection 1: Violation of GWL causes frost protection to start

F	Function	WE	Meaning
16	Function of switching output	3	1: Not active 2: Fault alarm 3: Circulation pump (DHW) 4: Circulation pump (heating) 5: Tapping 6: Circulation pump (heating) reversed ¹⁾
17	Pump protection ¹⁾	1	0: No 1: Yes

¹⁾ Firmware version 2.20 and higher

Parameter list

The parameters have the setting ranges as listed below.

P = Parameter

WE = Default setting

P	Parameters	WE	Adjustment range
01	Set point W1	60 °C	0 to 100 °C
02	Set point W2	70 °C	0 to 100 °C
03	Lower measuring range value Xmin	0 °C	-50 to 90 °C
04	Upper measuring range value Xmax	100 °C	10 to 150 °C
05	Upper limit (GWH)	95 °C	0 to 100 °C
06	Lower limit (GWL)	5 °C	0 to 20 °C
07	Proportional-action coefficient KP	0.8	0.1 to 50
08	Reset time Tn	15 s	0 to 999 s
09	Derivative-action time Tv	0 s	0 to 999 s
10	Actuator transit time Ty	25 s	0 to 240 s
11	Set-back difference	8 K	0 to 30 K
12	Heating period to maintain heat exchanger at constant temperature ¹⁾	24.0 h	0 to 25.5 h

¹⁾ Firmware version 2.20 and higher

5.1 Customer setting

Station	
Operator	
SAMSON office	

Function blocks		
F	WE	Performed setting
01	1	
02	1	
03	1	
04	0	
05	0	
06	0	
07	0	
08	0	
09	0	
10	0	
11	0	
16	1	
17	1	

Parameters			
P	WE	Performed setting	Adjustment range
01	60 °C		0 to 100 °C
02	70 °C		0 to 100 °C
03	0 °C		-50 to 90 °C
04	100 °C		10 to 150 °C
05	95 °C		0 to 100 °C
06	5 °C		0 to 20 °C
07	0.6		0.1 to 50
08	25 s		0 to 999 s
09	0 s		0 to 999 s
10	35 s		0 to 240 s
11	8 K		0 to 30 K
12	24.0 h		0 to 25.5 h



SAMSON AG · MESS- UND REGELTECHNIK
Weismüllerstraße 3 · 60314 Frankfurt am Main, Germany
Phone: +49 69 4009-0 · Fax: +49 69 4009-1507
samson@samson.de · www.samson.de

KH 5757 EN

2016-10-25 · English