

# MOUNTING AND OPERATING INSTRUCTIONS



## EB 4749 EN

Translation of original instructions



## Type 4749 Position Transmitter

Firmware version 1.00.02



Edition December 2020

## Note on these mounting and operating instructions

These mounting and operating instructions assist you in mounting and operating the device safely. The instructions are binding for handling SAMSON devices. The images shown in these instructions are for illustration purposes only. The actual product may vary.

- For the safe and proper use of these instructions, read them carefully and keep them for later reference.
- If you have any questions about these instructions, contact SAMSON's After-sales Service ([aftersaleservice@samsongroup.com](mailto:aftersaleservice@samsongroup.com)).



Documents relating to the device, such as the mounting and operating instructions, are available on our website at [www.samsongroup.com](http://www.samsongroup.com) > **Service & Support > Downloads > Documentation.**

## Definition of signal words

### **DANGER**

*Hazardous situations which, if not avoided, will result in death or serious injury*

### **WARNING**

*Hazardous situations which, if not avoided, could result in death or serious injury*

### **NOTICE**

*Property damage message or malfunction*

### **Note**

*Additional information*

### **Tip**

*Recommended action*

<b>1</b>	<b>Safety instructions and measures</b> .....	<b>1-1</b>
1.1	Notes on possible severe personal injury .....	1-3
1.2	Notes on possible personal injury .....	1-4
1.3	Notes on possible property damage .....	1-5
<b>2</b>	<b>Markings on the device</b> .....	<b>2-1</b>
2.1	Nameplate .....	2-1
2.2	Article code .....	2-2
<b>3</b>	<b>Design and principle of operation</b> .....	<b>3-1</b>
3.1	Device overview and operating controls .....	3-1
3.2	Technical data .....	3-2
3.3	Dimensions in mm .....	3-5
3.3.1	Fixing levels according to VDI/VDE 3845 (September 2010) .....	3-6
<b>4</b>	<b>Shipment and on-site transport</b> .....	<b>4-1</b>
4.1	Accepting the delivered goods .....	4-1
4.2	Removing the packaging from the position transmitter .....	4-1
4.3	Transporting the position transmitter .....	4-1
4.4	Storing the position transmitter .....	4-1
<b>5</b>	<b>Installation</b> .....	<b>5-1</b>
5.1	Installation conditions .....	5-1
5.2	Preparation for installation .....	5-2
5.2.1	Lever and pin position .....	5-2
5.3	Direct attachment to Type 3277 and Type 3277-5 Actuators .....	5-4
5.4	Attachment according to IEC 60534-6 (NAMUR rib) .....	5-6
5.5	Attachment to Type 3510 Micro-flow Valve .....	5-8
5.6	Attachment to rotary actuators according to VDI/VDE 3845 .....	5-10
5.6.1	Light version .....	5-10
5.6.2	Heavy-duty version .....	5-12
5.7	Establishing electrical connections .....	5-14
5.8	Mounting accessories .....	5-17
<b>6</b>	<b>Operation</b> .....	<b>6-1</b>
6.1	Operator keys and menu structure .....	6-1
6.2	Locking the configuration .....	6-3

## Contents

<b>7</b>	<b>Start-up .....</b>	<b>7-1</b>
7.1	Determining the mounting situation .....	7-2
7.2	Determining the position at 4 mA .....	7-2
7.2.1	Determining the position at 20 mA .....	7-3
7.2.2	Issuing a test current .....	7-4
<b>8</b>	<b>Operation .....</b>	<b>8-1</b>
8.1	Resetting the position transmitter to default settings .....	8-2
<b>9</b>	<b>Malfunctions .....</b>	<b>9-1</b>
9.1	Troubleshooting .....	9-1
9.2	Emergency action .....	9-1
<b>10</b>	<b>Servicing.....</b>	<b>10-1</b>
10.1	Periodic inspection and testing of the position transmitter .....	10-2
<b>11</b>	<b>Decommissioning .....</b>	<b>11-1</b>
<b>12</b>	<b>Removal .....</b>	<b>12-1</b>
<b>13</b>	<b>Repairs .....</b>	<b>13-1</b>
13.1	Servicing explosion-protected devices .....	13-1
13.2	Returning devices to SAMSON .....	13-2
<b>14</b>	<b>Disposal.....</b>	<b>14-1</b>
<b>15</b>	<b>Certificates .....</b>	<b>15-1</b>
<b>16</b>	<b>Annex.....</b>	<b>16-1</b>
16.1	After-sales service .....	16-1

# 1 Safety instructions and measures

## Intended use

The SAMSON Type 4749 Position Transmitter is mounted onto control valves and converts the linear or rotary motion of a control valve into a 4 to 20 mA standardized signal. The device is designed to operate under exactly defined conditions (e.g. temperature). Therefore, operators must ensure that the position transmitter is only used in applications where the operating conditions correspond to the technical data. In case operators intend to use the position transmitter in other applications or conditions than specified, contact SAMSON.

SAMSON does not assume any liability for damage resulting from the failure to use the device for its intended purpose or for damage caused by external forces or any other external factors.

➔ Refer to the technical data for limits and fields of application as well as possible uses.

## Reasonably foreseeable misuse

The Type 4749 Position Transmitter is **not** suitable for the following applications:

- Use outside the limits defined during sizing and by the technical data

Furthermore, the following activities do not comply with the intended use:

- Use of non-original spare parts
- Performing maintenance activities not described in these instructions

## Qualifications of operating personnel

The position transmitter must be mounted, started up and serviced by fully trained and qualified personnel only; the accepted industry codes and practices must be observed. According to these mounting and operating instructions, trained personnel refers to individuals who are able to judge the work they are assigned to and recognize possible hazards due to their specialized training, their knowledge and experience as well as their knowledge of the applicable standards.

Explosion-protected versions of this device must be operated only by personnel who has undergone special training or instructions or who is authorized to work on explosion-protected devices in hazardous areas.

## **Safety instructions and measures**

### **Personal protective equipment**

No personal protective equipment is required for the direct handling of the position transmitter. Work on the control valve may be necessary when mounting or removing the device.

- Observe the requirements for personal protective equipment specified in the valve documentation.
- Check with the plant operator for details on further protective equipment.

### **Revisions and other modifications**

Revisions, conversions or other modifications of the product are not authorized by SAMSON. They are performed at the user's own risk and may lead to safety hazards, for example. Furthermore, the product may no longer meet the requirements for its intended use.

### **Warning against residual hazards**

To avoid personal injury or property damage, plant operators and operating personnel must prevent hazards that could be caused in the control valve by the process medium, the operating pressure, the signal pressure or by moving parts by taking appropriate precautions. Plant operators and operating personnel must observe all hazard statements, warning and caution notes in these mounting and operating instructions, especially for installation, start-up and service work.

If inadmissible motions or forces are produced in the pneumatic actuator as a result of the supply pressure, it must be restricted using a suitable supply pressure reducing station.

### **Responsibilities of the operator**

The operator is responsible for proper operation and compliance with the safety regulations. Operators are obliged to provide these mounting and operating instructions to the operating personnel and to instruct them in proper operation. Furthermore, the operator must ensure that operating personnel or third parties are not exposed to any danger.

### **Responsibilities of operating personnel**

Operating personnel must read and understand these mounting and operating instructions as well as the specified hazard statements, warning and caution notes. Furthermore, the operating personnel must be familiar with the applicable health, safety and accident prevention regulations and comply with them.

### **Referenced standards and regulations**

Devices with a CE marking fulfill the requirements of the Directives RoHS 2011/65/EU as well as 2014/30/EU and, depending on the version, 2014/34/EU for explosion-protected applications. This EU declaration of conformity is included in the annex of this document.

### Referenced documentation

The following documents apply in addition to these mounting and operating instructions:

- The mounting and operating instructions of the components on which the position transmitter is mounted (valve, actuator, valve accessories etc.).

## 1.1 Notes on possible severe personal injury

### DANGER

#### **Risk of fatal injury due to the ignition of an explosive atmosphere.**

Incorrect installation, operation or maintenance of the position transmitter in potentially explosive atmospheres may lead to ignition of the atmosphere and ultimately to death, even with a harmless supply voltage.

- For mounting and electrical installation in hazardous areas, observe the explosion protection approvals as well as the relevant electrotechnical regulations and the accident prevention regulations that apply in the country of use. EN 60079-14 applies in Europe.
- Do not connect the electrical supply before mounting is completed.
- Installation, operation or maintenance of the position transmitter must only be performed by personnel with qualifications according to Clause 4.5 of IEC 60079-14 who has undergone special training or instructions or who is authorized to work on explosion-protected devices in hazardous areas.

#### **Risk of fatal injury as a result of electrostatic discharge at the device.**

An electric spark generated by electrostatic discharge may lead to ignition of a potentially explosive atmosphere and cause death.

- In hazardous areas, mount the device in such a way that electrostatic charging cannot take place.

#### **Loss of the explosion protection due to damage to the cover's thread and/or the connecting thread.**

- Do not open devices with flameproof enclosures while they are energized.

## 1.2 Notes on possible personal injury

### **WARNING**

#### **Crush hazard arising from moving parts on the valve and actuator.**

Control valves contain moving parts (actuator and plug stem), which can injure hands or fingers if inserted into the valve.

- Do not touch any moving valve parts while the control valve is in operation.
- Before performing any mounting or installation work on the position transmitter, put the control valve out of operation by disconnecting and locking the supply and control signal.

#### **Incorrect electrical connection will render the explosion protection unsafe.**

- Adhere to the terminal assignment.
- Do not undo the enameled screws.
- Do not exceed the maximum permissible values specified in the EC type examination certificates when interconnecting intrinsically safe electrical equipment ( $U_i$  or  $U_o$ ,  $I_i$  or  $I_o$ ,  $P_i$  or  $P_o$ ,  $C_i$  or  $C_o$  and  $L_i$  or  $L_o$ ).

#### **The use of unapproved cable glands will render the explosion protection unsafe.**

- For devices with flameproof enclosure, only use cable glands and screw plugs which are approved for type of protection Ex d and the certified temperature range.

#### **Opening the position transmitter in potentially explosive dust atmospheres will render the explosion protection unsafe.**

- Do not open the enclosure cover of the position transmitter in potentially explosive dust atmospheres.



## 1.3 Notes on possible property damage

### ! NOTICE

#### **Risk of malfunction due to incorrect mounting parts/accessories or incorrect assignment of lever and pin position.**

- Only use mounting parts/accessories listed in these mounting and operating instructions to mount the position transmitter.
- Observe the type of attachment.
- Observe the assignment between lever and pin position.

#### **Risk of malfunction due to calibration not being performed.**

The zero and span calibration allow the position transmitter to be adapted to the mounting situation. The position transmitter is only ready for operation after the zero and span have been calibrated.

- Perform calibration before initial start-up.
- Calibrate the position transmitter after changing the mounting position.

#### **Risk of position transmitter damage due to incorrect grounding of the electric welding equipment.**

- Do not ground electric welding equipment near to the position transmitter.



## 2 Markings on the device

### 2.1 Nameplate

#### Explosion-protected version

Types 4749-11x and 4749-21x

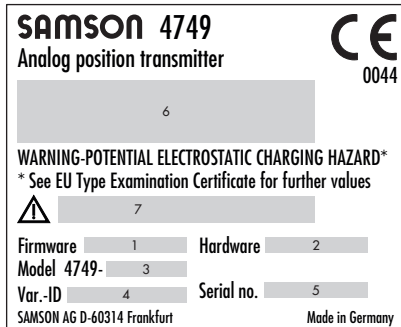

Type 4749-18x

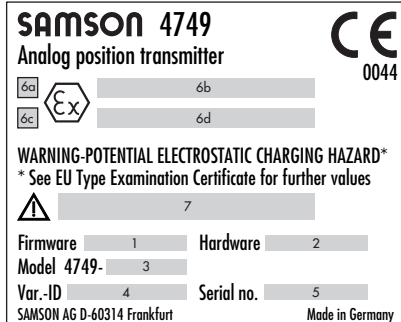

<sup>1)</sup> The first two figures of the serial number in reverse order indicate the year of manufacture (example: serial number 71xxxx → Year of manufacture = 2017).

#### Type of protection code for Type 4749-18x

→ Before mounting the position transmitter, check the box for the type of protection required for the ambient conditions on the nameplate (checkbox 6a for type of protection Ex i or checkbox 6c for type of protection Ex d).

#### Version without explosion protection

All types

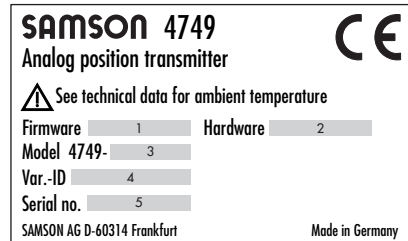

- 1 Firmware version
- 2 Hardware version
- 3 Model number
- 4 Configuration ID
- 5 Serial number <sup>1)</sup>
- 6 Type of protection code
- 6a Checkbox for type of protection Ex i
- 6b Type of protection Ex i
- 6c Checkbox for type of protection Ex d
- 6d Type of protection Ex d
- 7 Temperature limits in the test certificates for the explosion-protected devices

## Markings on the device

### 2.2 Article code

Position transmitter		Type 4749-	x	x	x	x	0	x	x	x	x	0	0	x	x	x	x	
Version																		
Analog position transmitter						0												
Explosion protection																		
Without			0	0	0													
ATEX	II 2 G Ex ia IIC T6...T4 Gb/ II 2 D Ex ia IIIIC T85 °C Db		1	1	0													
	-----																	
IECEx	Ex ia IIC T6...T4 Gb/ Ex ia IIIIC T85 °C Db		1	1	1													
	-----																	
ATEX	II 2 G Ex ia IIC T6...T4 Gb II 2 D Ex ia IIIIC T85 °C Db		1	8	0													
	or																	
	II 2 G Ex db IIC T6...T4 Gb II 2 D Ex tb IIIIC T80 °C Db																	
-----																		
IECEx	Ex ia IIC T6...T4 Gb Ex ia IIIIC T85 °C Db		1	8	1													
	or																	
	Ex db IIC T6...T4 Gb Ex tb IIIIC T80 °C Db																	
-----																		
ATEX	II 2 G Ex db IIC T6...T4 Gb/ II 2 D Ex tb IIIIC T80 °C Db		2	1	0													
	-----																	
IECEx	Ex db IIC T6...T4 Gb/ Ex tb IIIIC T80 °C Db		2	1	1													
Electrical threaded connection																		
M20x1.5						0												
½ NPT						1												
Enclosure material																		
Aluminum (standard)						0												
Special applications																		
Without									0									
Temperature range																		
-20 to +85 °C (standard)										0								
-40 to +85 °C (with metal cable glands)																		

Position transmitter	Type 4749-	x	x	x	x	0	x	x	x	x	0	0	x	x	x	x
Hardware version													9	9		
1.00.00																
Firmware version																
1.00.02															9	8



### 3 Design and principle of operation

The Type 4749 Position Transmitter converts the linear or rotary motion of a control valve into an electric 4 to 20 mA standardized signal.

The angle of the position transmitter's axis is measured by the magnetoresistive measuring system and converted into an electric signal.

Two pushbuttons are used to operate the device and make device settings. Two LEDs (red and green) indicate the menu items and settings.

To operate the position transmitter, a transmitter supply voltage of  $U_B = 12$  to  $36$  V is required for the 4 to 20 mA measuring circuit.

#### 3.1 Device overview and operating controls

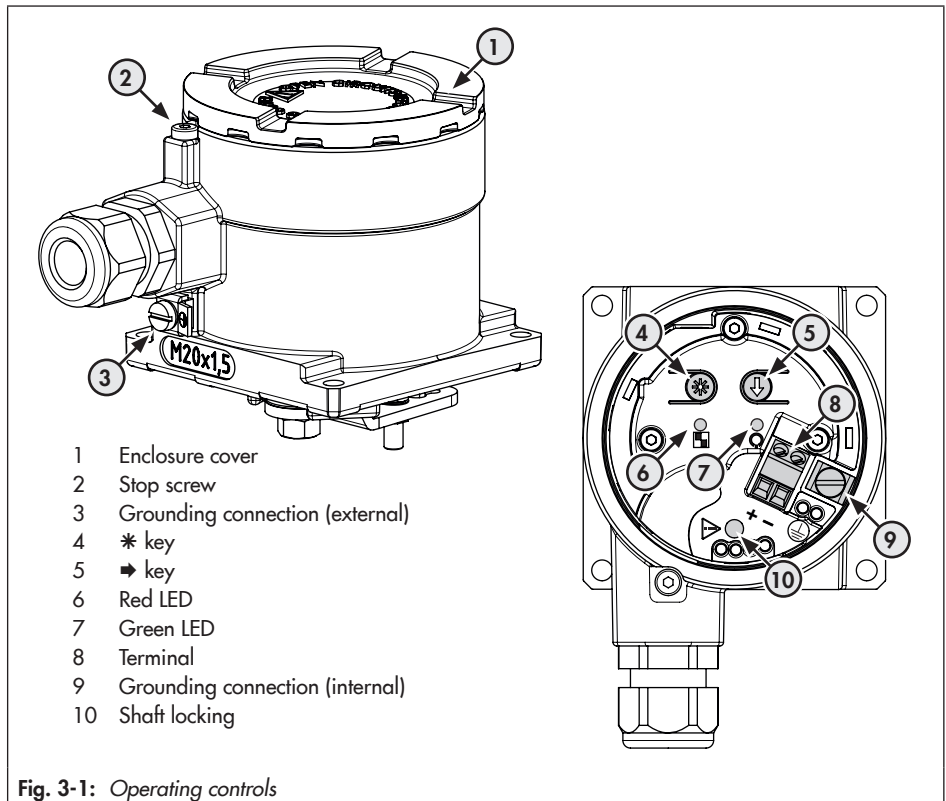

Fig. 3-1: Operating controls

## 3.2 Technical data



Type 4749 Position Transmitter		
<b>Measuring range</b>		
Measurement method	Magnetoresistive measuring system	
Measured travel for	Direct attachment to Type 3277:	3.6 to 30 mm
	Attachment according to IEC 60534-6 (NAMUR):	5 to 300 mm
	Attachment to rotary actuators:	24 to 100°
<b>Power supply</b>		
Input voltage	12 to 36 V DC	
Output	4 to 20 mA · Two-wire device, reverse polarity protection	
Residual current	≤3.6 mA	
Permissible load $R_B$ in $\Omega$	$R_B = (U_B - 12 \text{ V})/0.020 \text{ A}$	
Static destruction limit	38 V DC, 30 V AC	
Power consumption	<0.2 W	
<b>Measuring accuracy</b>		
Reference conditions	Calibrated with $U = 24 \text{ V DC}$ , $T_U = 20 \text{ °C}$	
Zero error	<0.1 % according to DIN EN 60770	
Hysteresis	≤0.1 % according to DIN EN 60770	
Nonlinearity	<0.3 % according to DIN EN 60770	
Effect of supply voltage on zero and span	<0.05 % according to DIN EN 60770	
Effect of ambient temperature on zero and span	<0.1 %/10 K according to DIN EN 60770	
Long-term stability	<0.1 % according to DIN EN 60770	
Start-up time	1200 ms	
Output rate	1 ms	



<b>Environmental conditions and permissible temperatures</b>	
Permissible environmental conditions according to EN 60721-3	
Storage	1K6 (relative humidity $\leq 95\%$ )
Transport	2K4
Operation	4K2 or 4K3 (depending on the temperature range) -20 to +85 °C: All versions -40 to +85 °C: With metal cable glands Observe the limits in the test certificate for explosion-protected versions.
Resistance to vibration	
Vibrations (sinusoidal)	According to DIN EN 60068-2-6: 2 to 9 Hz; 3.5 mm amplitude 10 to 200 Hz; 10 m/s <sup>2</sup> acceleration 200 to 500 Hz; 15 m/s <sup>2</sup> acceleration
Noise	According to DIN EN 60068-2-64: 10 to 200 Hz; amplitude 1 (m/s <sup>2</sup> ) <sup>2</sup> /Hz 200 to 2000 Hz; amplitude 0.3 (m/s <sup>2</sup> ) <sup>2</sup> /Hz
<b>Requirements</b>	
EMC	Complying with EN 61000-6-1, EN 61000-6-2, EN 61000-6-3, EN 61000-6-4, EN 61000-6-7, EN 61326 and NAMUR Recommendation NE 21
Degree of protection	IP 66
Conformity	<b>CE</b>
<b>Electrical connections</b>	
Cable glands	M20x1.5 or ½ NPT
Terminals	Screw terminals for 0.2 to 2.5 mm <sup>2</sup> wire cross-section
<b>Explosion protection</b>	
ATEX, IECEx	See 'Summary of explosion protection approvals' on page 3-4.
<b>Materials</b>	
Enclosure and cover	Die-cast aluminum EN AC-44300/EN AC-43000 according to DIN EN 1706, chromated and powder paint coated
Cable glands	Polyamide, nickel-plated brass
Other external parts	Stainless steel 1.4301/1.4310 + 1.4404/1.4409 (316 L)
<b>Weight</b>	0.7 kg

## Design and principle of operation

### Summary of explosion protection approvals

Type	Certification		Type of protection	
4749-110	 EC type examination certificate	Number Date	KIWA 18ATEX0031 X 2019-01-09	II 2 G Ex ia IIC T6...T4 Gb/ II 2 D Ex ia IIIC T85 °C Db
4749-111	IECEX	Number Date	IECEX KIWA 18.0014X 2019-01-09	Ex ia IIC T6...T4 Gb/ Ex ia IIIC T85 °C Db
4749-180	 EC type examination certificate	Number Date	KIWA 19ATEX0038 X 2019-10-10	II 2 G Ex ia IIC T6...T4 Gb II 2 D Ex ia IIIC T85 °C Db or II 2 G Ex db IIC T6...T4 Gb II 2 D Ex tb IIIC T80 °C Db
4749-181	IECEX	Number Date	IECEX KIWA 19.0022X 2019-10-10	Ex ia IIC T6...T4 Gb Ex ia IIIC T85 °C Db or Ex db IIC T6...T4 Gb Ex tb IIIC T80 °C Db
4749-210	 EC type examination certificate	Number Date	KIWA 18ATEX0036 X 2018-11-11	II 2 G Ex db IIC T6...T4 Gb/ II 2 D Ex tb IIIC T80 °C Db
4749-211	IECEX	Number Date	IECEX KIWA 18.0017X 2018-11-11	Ex db IIC T6...T4 Gb/ Ex tb IIIC T80 °C Db

### 3.3 Dimensions in mm

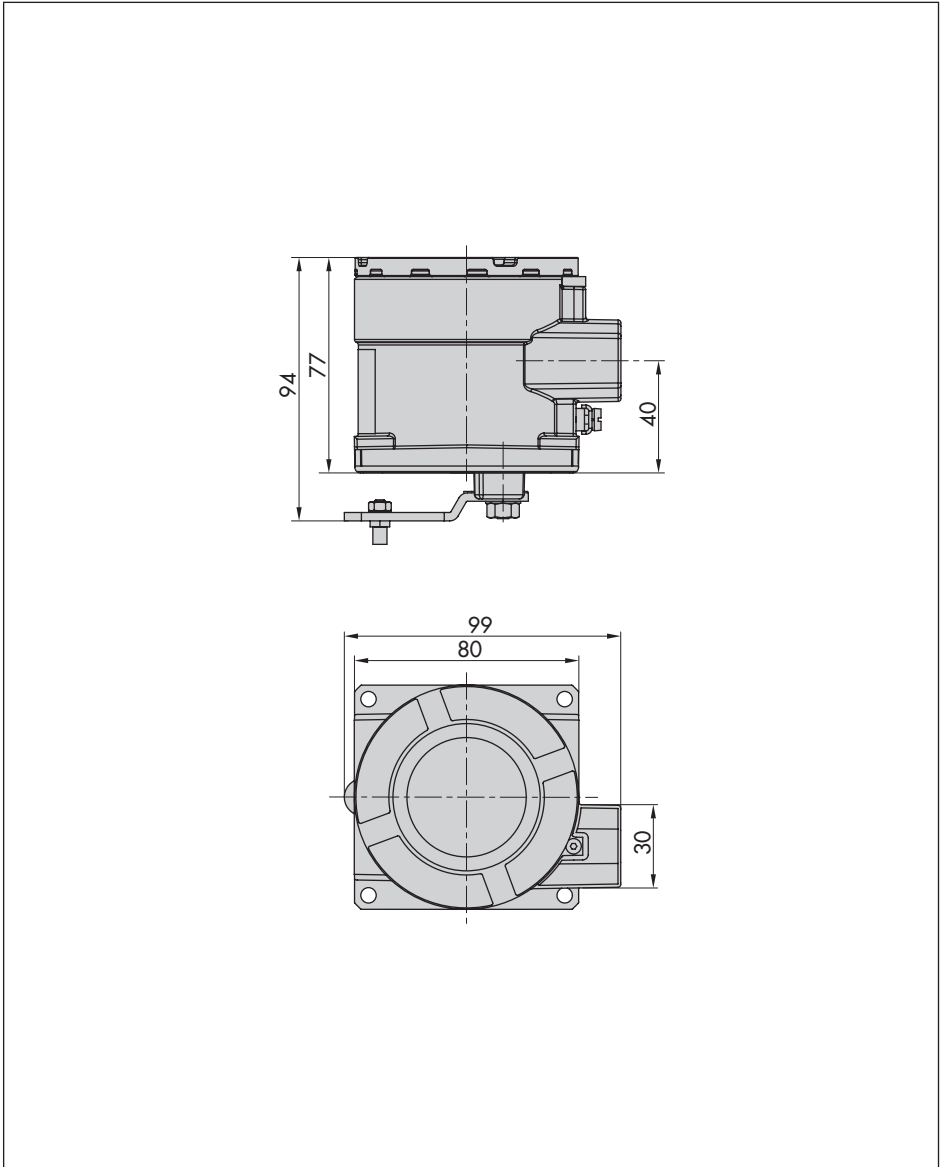

### 3.3.1 Fixing levels according to VDI/VDE 3845 (September 2010)

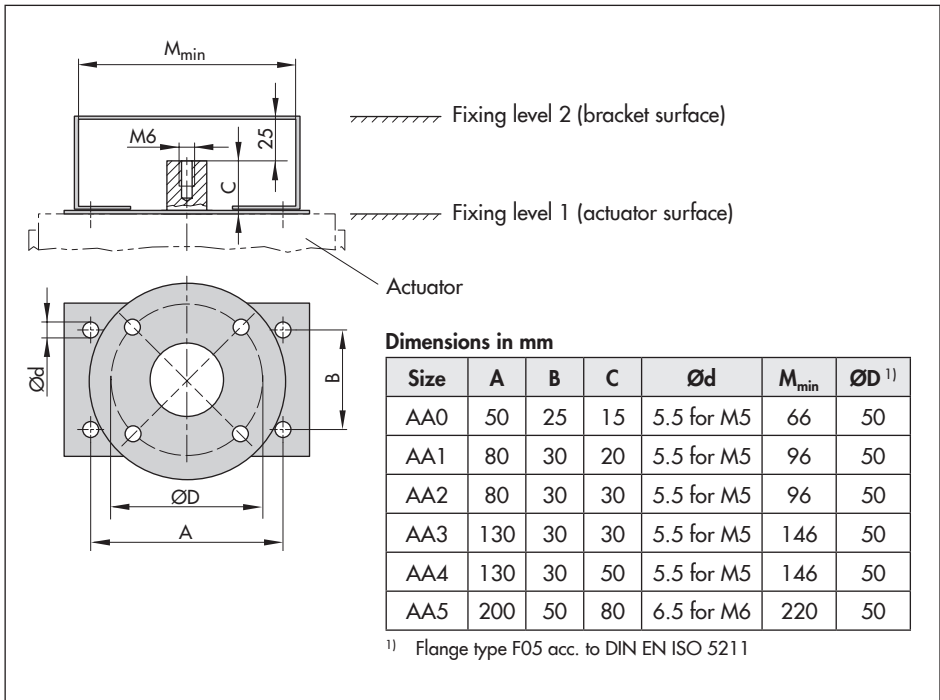

## 4 Shipment and on-site transport

The work described in this section is only to be performed by personnel appropriately qualified to carry out such tasks.

### 4.1 Accepting the delivered goods

After receiving the shipment, proceed as follows:

1. Check the scope of delivery. Check that the specifications on the nameplate and on the position transmitter itself match the specifications in the delivery note. See the 'Markings on the device' section for nameplate details.
2. Check the shipment for transportation damage. Report any damage to SAMSON and the forwarding agent (refer to delivery note).

### 4.2 Removing the packaging from the position transmitter

Observe the following sequence:

- Do not remove the packaging until immediately before installation of the position transmitter.
- Dispose and recycle the packaging in accordance with the local regulations.

### 4.3 Transporting the position transmitter

#### Transport instructions

- Protect the position transmitter against external influences (e.g. impact).
- Protect the position transmitter against moisture and dirt.
- Observe transport temperature depending on the permissible ambient temperature (see the 'Design and principle of operation' section).

### 4.4 Storing the position transmitter

---

#### ! NOTICE

***Risk of damage to the position transmitter due to improper storage.***

- *Observe the storage instructions.*
  - *Avoid long storage times.*
  - *Contact SAMSON in case of different storage conditions.*
- 

#### ! Note

*We recommend regularly checking the prevailing storage conditions during long storage periods.*

---

## Shipment and on-site transport

### Storage instructions

- Protect the position transmitter against external influences (e.g. impact, shocks, vibration).
- Do not damage the corrosion protection (coating).
- Protect the position transmitter against moisture and dirt. In damp spaces, prevent condensation. If necessary, use a drying agent or heating.
- Observe storage temperature depending on the permissible ambient temperature (see the 'Design and principle of operation' section).
- Do not place any objects on the position transmitter.

## 5 Installation

The work described in this section is only to be performed by personnel appropriately qualified to carry out such tasks.

### **⚠ DANGER**

**Risk of fatal injury as a result of electrostatic discharge at the device.**

- ➔ In hazardous areas, mount the device in such a way that electrostatic charging cannot take place.

### **⚠ WARNING**

**Crush hazard arising from moving parts on the valve and actuator.**

- ➔ Before performing any mounting or installation work on the position transmitter, put the control valve out of operation by disconnecting and locking the supply and control signal.

The position transmitter is suitable for the following types of attachment:

- Direct attachment to SAMSON Type 3277 Actuator
- Attachment to actuators according to IEC 60534-6 (NAMUR rib)
- Attachment to Type 3510 Micro-flow Valve
- Attachment to rotary actuators according to VDI/VDE 3845

### **ⓘ NOTICE**

**Risk of malfunction due to incorrect mounting parts/accessories or incorrect assignment of lever and pin position.**

- ➔ Only use the accessories listed in section 5.8 to mount the position transmitter.
- ➔ Observe the type of attachment.
- ➔ Observe the assignment between lever and pin position.

### **Type 4749-18x only:**

- ➔ Before mounting the position transmitter, check the box for the type of protection required for the ambient conditions on the nameplate (checkbox 6a for type of protection Ex i or checkbox 6c for type of protection Ex d). See the 'Markings on the device' section.

## 5.1 Installation conditions

### **Work position**

The work position for the position transmitter is the front view onto the operating controls on the position transmitter seen from the position of operating personnel.

Plant operators must ensure that, after installation of the position transmitter, the operating personnel can perform all necessary work safely and easily access the device from the work position.

### **Mounting orientation**

The position transmitter may be installed in any position. The following applies concerning the installation:

## Installation

- On mounting, make sure that 300 mm or more clearance is kept above the enclosure cover.

### 5.2 Preparation for installation

Before installation, make sure the following conditions are met:

- The position transmitter is not damaged.

Proceed as follows:

- Lay out the necessary material and tools to have them ready during installation work.
- Put the control valve out of operation by disconnecting and locking the supply and control signal.
- Adjust correct lever and pin position (see section 5.2.1).

#### 5.2.1 Lever and pin position

The position transmitter is adapted to the actuator and to the rated travel by the lever on the bottom of the position transmitter and the pin inserted into the lever. The travel tables show the maximum adjustment range at the position transmitter.

The travel that can be implemented at the valve is additionally restricted by the required compression of the actuator springs.

If a pin position other than position **35** with the standard **M** lever is required or a different lever size is required, proceed as follows (see Fig. 5-1):

1. Place the lever (1) in mid-position and hold it in place. Unthread the nut (1.1) and remove the lever together with the disk spring (1.2) from the shaft.
  - Do not remove the tab washer (1.3).
2. Remove the follower pin (2) from its pin position and move it to the hole for the recommended pin position (according to travel tables) and screw tight. Only use the longer follower pin included in the mounting kit.
3. Place the lever (1) on the shaft of the position transmitter and fasten it tight using the disk spring (1.2) and nut (1.1).

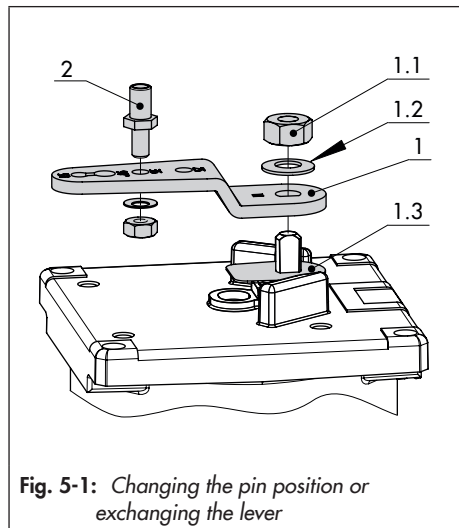



## Travel tables

**i Note**

The M lever is included in the scope of delivery.

S, L, XL levers for attachment according to IEC 60534-6 (NAMUR rib) are available as accessories in the mounting kits.

**Direct attachment to Type 3277-5 and Type 3277 Actuators**

Actuator area [cm <sup>2</sup> ]	Rated travel [mm]	Required lever	Assigned pin position
120	7.5	M	25
120/175/240/350	15	M	35
355/700/750	30	M	50

**Attachment according to IEC 60534-6 (NAMUR rib)**

SAMSON valves with Type 3271 Actuator		Other control valves	Required lever	Assigned pin position
Actuator area [cm <sup>2</sup> ]	Rated travel [mm]	Max. travel [mm]		
120 with Type 3510 Valve	7.5	17	S	17
120	7.5	25	M	25
120/175/240/350	15	35	M	35
700/750	7.5	35	M	35
355/700/750	15 and 30	50	M	50
1000/1400/2800	30	70	L	70
	60	100	L	100
1400/2800	120	200	XL	200

**Attachment according to VDI/VDE 3845 to rotary actuators**

Opening angle	Required lever	Assigned pin position
0 to 100°	M	90°

### 5.3 Direct attachment to Type 3277 and Type 3277-5 Actuators

- ➔ See Fig. 5-2 and Fig. 5-3
- ➔ Required mounting parts and accessories:  
see section 5.8.
- 1. Place follower clamp (4) on the actuator stem, align it and screw tight so that the fastening screw (3) is located in the groove of the actuator stem.
- 2. Fasten the mounting plate (1) onto the actuator yoke using both fastening screws (2).
- 3. Check the pin position of the follower pin (2) on the lever (1). Refer to travel tables for type of attachment. If necessary, change the pin position (see section 5.2.1).
- 4. Screw the stop screw into the housing cover and unscrew the cover.
- 5. Place the position transmitter on the mounting plate so that the follower pin rests on the top of the follower clamp (4):  
➔ Adjust the lever correspondingly and insert a thin screwdriver into the hole to lock the shaft in place. Keep the screwdriver in the hole to lock in position.
- 6. The lever must rest on the follower clamp with spring force. Fasten the position transmitter onto the actuator yoke using the four fastening screws (5).
- 7. Mount cover (6) on the other side. Make sure that the vent plug faces downward

(in cases where this is not possible, mount it in the horizontal position) when the control valve is installed to allow any condensed water that collects to drain off.

- 8. For Type 3277 Linear Actuators with "actuator stem retracts" fail-safe action, screw a vent plug (7) into the connection at the side of the yoke.
- 9. Mount the enclosure cover. Check the O-ring for damage and replace it, if necessary.
- 10. Lock the enclosure cover by unscrewing the stop screw.

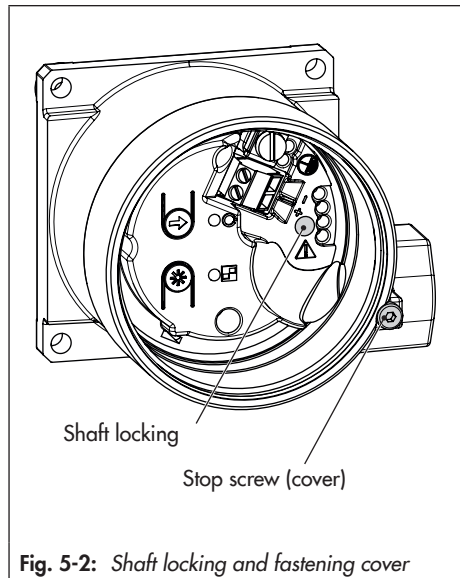
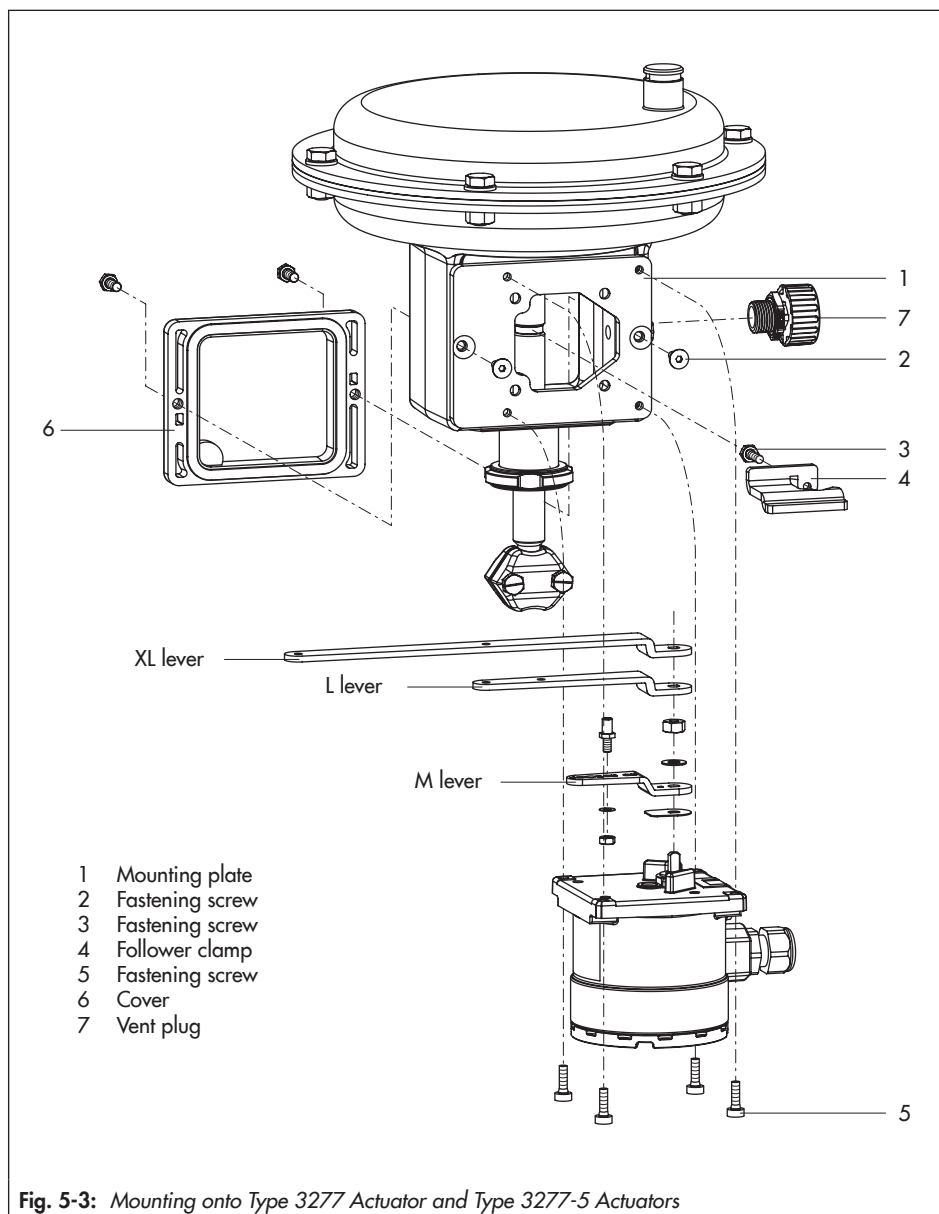
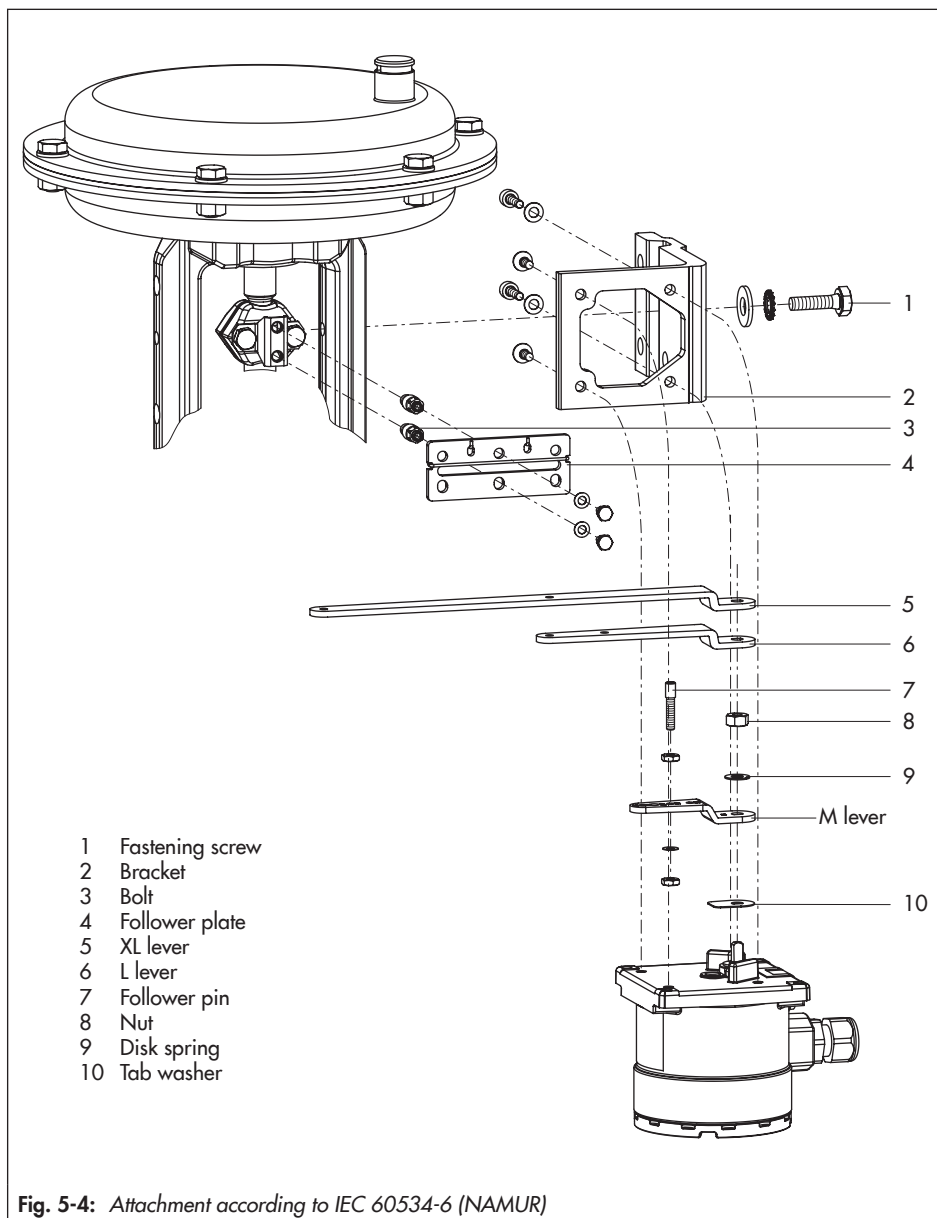

Fig. 5-2: Shaft locking and fastening cover



### 5.4 Attachment according to IEC 60534-6 (NAMUR rib)

- See Fig. 5-2 and Fig. 5-4
- Required mounting parts and accessories:  
see section 5.8.
- 1. Check the pin position of the follower pin (2) on the lever (1). Refer to travel tables for type of attachment. If necessary, change the pin position (see section 5.2.1).
- 2. Screw the stop screw into the enclosure cover and unscrew the cover.
- 3. Fasten the position transmitter onto the bracket (2).
- 4. Screw the two bolts (3) to the bracket of the stem connector, place the follower plate (4) on top and use the screws for fastening.
- 5. Place the bracket with position transmitter on the NAMUR rib of the valve in such a manner that the follower pin (7) rests in the slot of the follower plate (4):
  - Adjust the lever correspondingly and insert a thin screwdriver into the hole to lock the shaft in place. Keep the screwdriver in the hole to lock in position.
- 6. Align the middle of the bracket to the 50 % marking on the travel indicator scale and fasten it using its screw (1) onto the valve.



### 5.5 Attachment to Type 3510 Micro-flow Valve

- See Fig. 5-5
- Required mounting parts and accessories:  
see section 5.8.
- 1. Adapt the mounting position as described in section 5.2.1.
- Select the S lever (6) from the accessories and mount it onto the position transmitter.
- Screw the follower pin into the pin position 17.
- 2. Fasten the position transmitter on the bracket (3).
- 3. Place follower clamp (1) on the valve stem connector, align at a right angle and screw tight.
- 4. Position the bracket (3) with the position transmitter on the valve yoke and screw tight, making sure the follower pin (2) slides into the groove of the follower clamp (1).

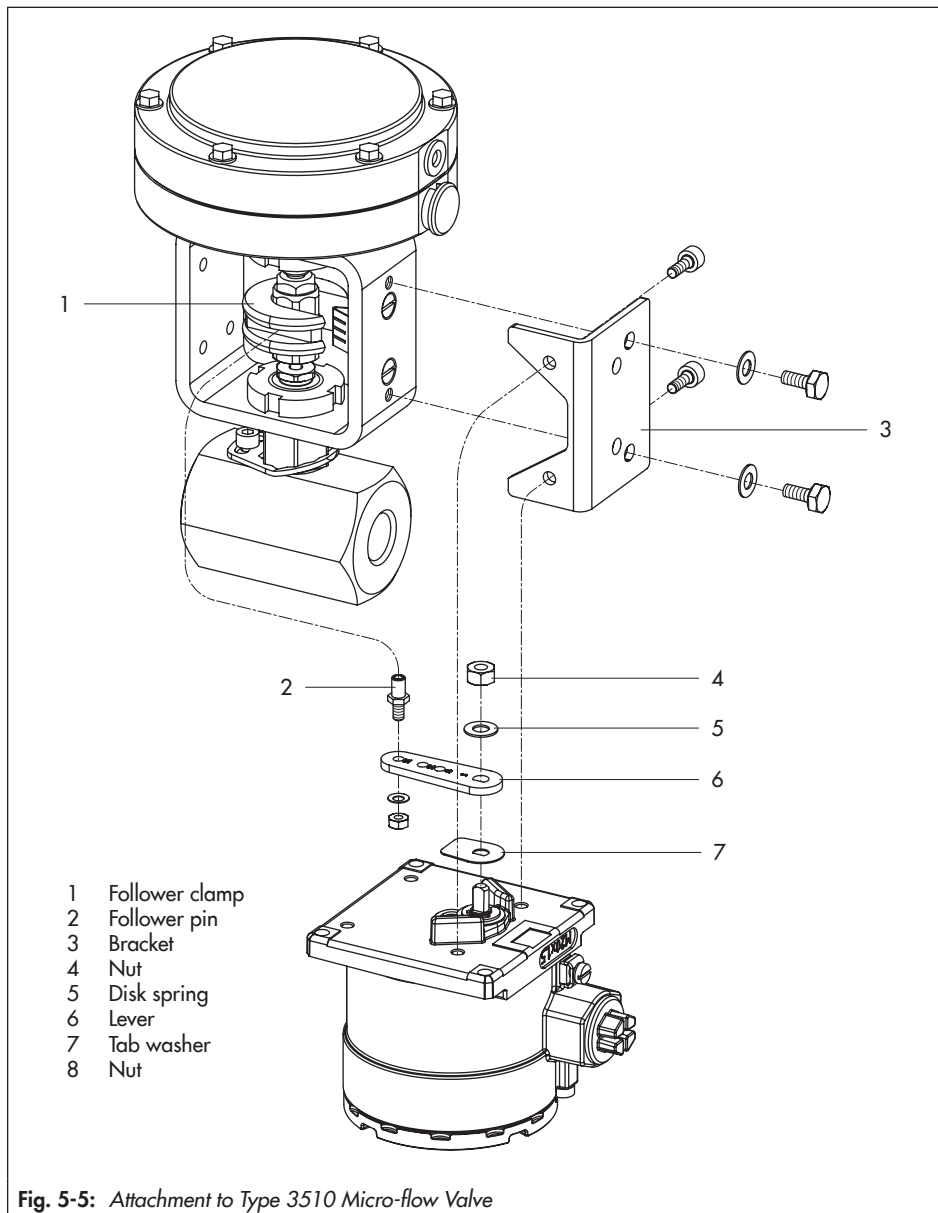

### 5.6 Attachment to rotary actuators according to VDI/VDE 3845

#### 5.6.1 Light version

→ See Fig. 5-6

→ Required mounting parts and accessories:  
see section 5.8.

1. Place follower clamp (2) on the slotted actuator shaft or spacer.
2. Place coupling wheel (3) with flat side facing the actuator on the follower clamp (2). Align slot so that it matches the direction of rotation when the valve is in its closed position.
3. Fasten the coupling wheel and follower clamp tightly onto the actuator shaft using screw and disk spring.
4. Fasten the bottom pair of brackets (4) with the bends pointing either facing to the inside (80 mm) or to the outside (130 mm) (depending on the actuator size). Position the top pair of brackets (5) and fasten.
5. Unscrew the standard follower pin from the position transmitter's M lever (1). Use the metal follower pin ( $\varnothing$  5 mm) included in the mounting kit and screw tight into the hole for pin position 90°.
6. Fasten the position transmitter onto the mounting plate (6).
7. Place the position transmitter together with the mounting plate on the top bracket (5) and screw it tight. Taking the actuator's direction of rotation into account, adjust lever (1) so that it engages in the slot of the coupling wheel (3) with its follower pin.

→ Adjust the lever correspondingly and insert a thin screwdriver into the hole to lock the shaft in place (see Fig. 5-2).

Keep the screwdriver in the hole to lock in position.

→ Make sure that the lever (1) is parallel to the long side of the position transmitter when the rotary actuator is at half its angle of rotation.

8. Stick the scale plate on the coupling wheel so that the arrow tip indicates the closed position and it can be easily read when the valve is installed.



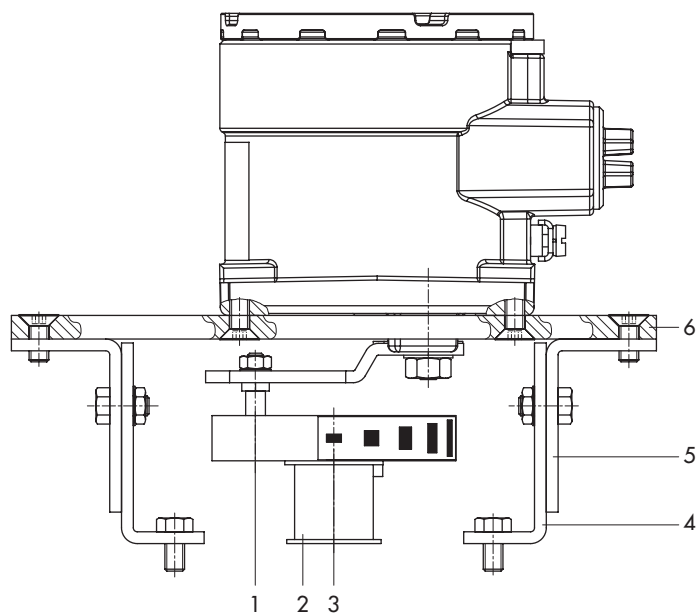

- 1 Lever
- 2 Follower clamp
- 3 Coupling wheel
- 4 Bottom pair of brackets
- 5 Top pair of brackets
- 6 Mounting plate

Fig. 5-6: Attachment to rotary actuators according to VDI/VDE 3845 (light version)

### 5.6.2 Heavy-duty version

- See Fig. 5-7
  - Required mounting parts and accessories:  
see section 5.8.
1. Prepare actuator and mount possibly required adapter supplied by the actuator manufacturer (only necessary for fixing level 2).
  2. Mount the housing (7) onto the rotary actuator. In case of VDI/VDE attachment, place spacers (8) underneath, if necessary.
  3. For SAMSON Type 3278, VETEC S160 and VETEC R Rotary Actuators, screw the adapter (6) with the supplementary adapter (depending on the mounting kit) onto the free end of the shaft of the actuator. For VDI/VDE version, only place on the adapter (6) when it is required for the actuator size.
  4. Stick adhesive label onto the coupling wheel (5) in such a manner that the yellow part of the sticker is visible in the window of the housing when the valve is OPEN. Adhesive labels with explanatory symbols are enclosed and can be stuck on the housing, if required.
  5. Fasten coupling wheel (5) on the slotted actuator shaft or adapter (6) using screw (3) and disk spring (4).
  6. Unscrew the standard follower pin from the position transmitter's M lever (1). Attach the follower pin (Ø5 mm) included in the mounting kit to pin position 90°.
  7. Fasten the position transmitter onto the mounting plate (2).
  8. Place the position transmitter together with the mounting plate on the housing (7) and screw it tight. Taking the actuator's direction of rotation into account, adjust lever (1) so that it engages in the correct slot with its follower pin:
    - Adjust the lever correspondingly and insert a thin screwdriver into the hole to lock the shaft in place (see Fig. 5-2). Keep the screwdriver in the hole to lock in position.

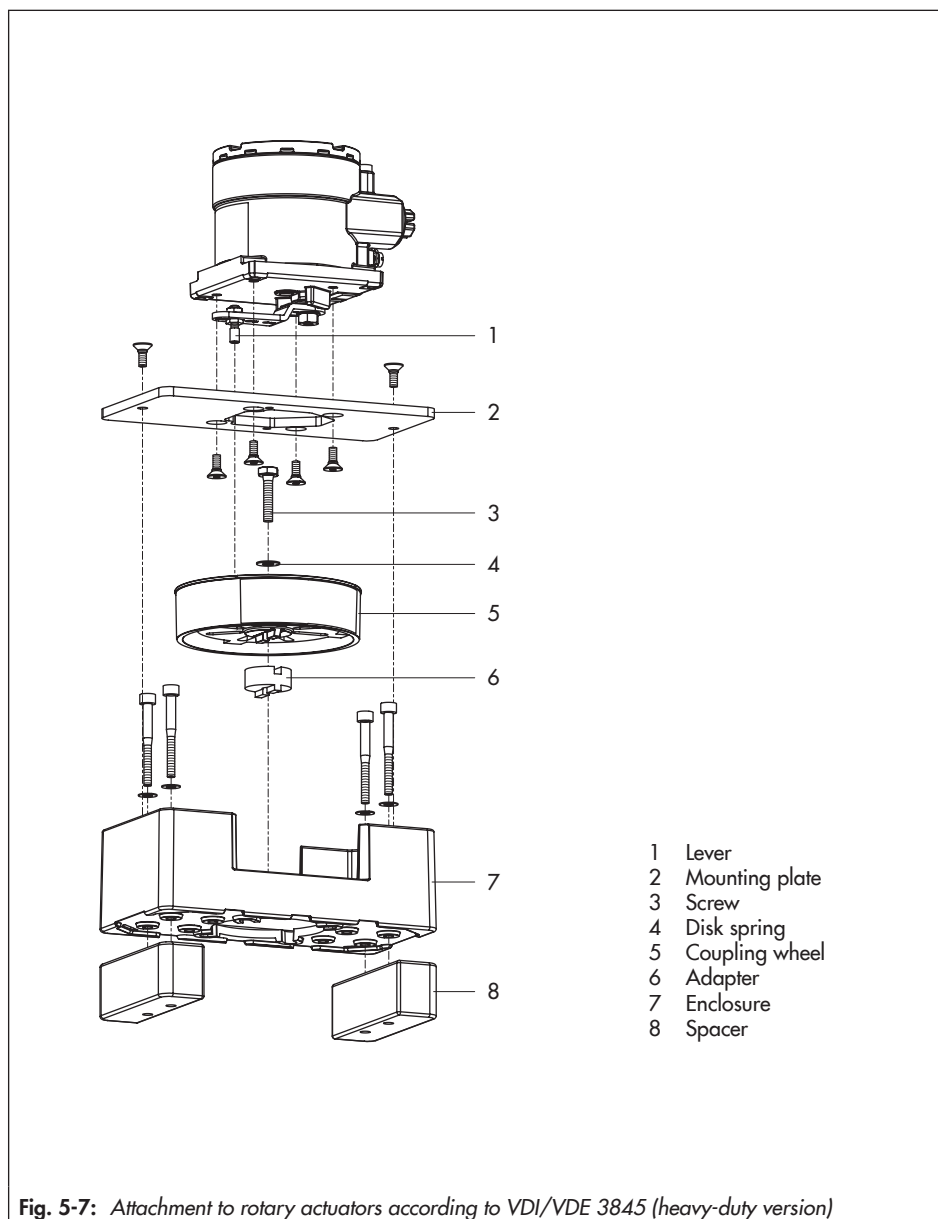

## 5.7 Establishing electrical connections

### **⚠ DANGER**

**Risk of fatal injury due to the ignition of an explosive atmosphere.**

- For mounting and electrical installation in hazardous areas, observe the explosion protection approvals as well as the relevant electrotechnical regulations and the accident prevention regulations that apply in the country of use. EN 60079-14 applies in Europe.
- Do not connect the electrical supply before mounting is completed.
- Installation, operation or maintenance of the position transmitter must only be performed by personnel with qualifications according to Clause 4.5 of IEC 60079-14 who has undergone special training or instructions or who is authorized to work on explosion-protected devices in hazardous areas.

### **⚠ WARNING**

**Incorrect electrical connection will render the explosion protection unsafe.**

- Adhere to the terminal assignment.
- Do not undo the enameled screws.
- Do not exceed the maximum permissible values specified in the EC type examination certificates when interconnecting intrinsically safe electrical equipment ( $U_i$  or  $U_o$ ,  $I_i$  or  $I_o$ ,  $P_i$  or  $P_o$ ,  $C_i$  or  $C_o$  and  $L_i$  or  $L_o$ ).

### **Cable entries**

- Fit equipment used in ambient temperatures below  $-20\text{ °C}$  with metal cable entries.

### **Equipment with type of protection Ex i**

Observe Clause 12 of EN 60079-14 for installation of the intrinsically safe circuits.

Use heat-resistant cables and cable glands that are suitable for a temperature of at least 20 K above the maximum ambient temperature.

Only use cable entries and conduit systems which are suitable for a degree of protection  $\geq$  IP 66 and the certified temperature range.

### **Equipment with type of protection Ex d**

### **⚠ DANGER**

**Loss of the explosion protection due to damage to the cover's thread and/or the connecting thread.**

- Do not open devices with flameproof enclosures while they are energized.

### **⚠ WARNING**

**The use of unapproved cable glands will render the explosion protection unsafe.**

- Only use cable glands and screw plugs which are approved for type of protection Ex d and the certified temperature range.

Connect the devices using suitable cable entries or conduit systems that comply with EN 60079-1 Explosive Atmospheres – Part 1: Equipment Protection by Flameproof

Enclosures "d", Clauses 13.1 and 13.2 and for which a separate test certificate is available.

Do not use cable entries and blanking plugs of simple construction.

- Install the connecting cable properly so that it is protected against mechanical damage.
- If the temperature at the entry parts exceeds 70 °C, use a temperature-resistant connecting cable:
  - For Ex db T6 only use cables and cable glands which are suitable for the temperature range from –55 to +85 °C.
  - For Ex db T5 only use cables and cable glands which are suitable for the temperature range from –55 to +100 °C.
  - For Ex db T4 only use cables and cable glands which are suitable for the temperature range from –55 to +105 °C.
- Include the enclosure of the position transmitter in the on-site equipotential bonding system. Use the external grounding connection on the enclosure.

## Equipment with type of protection Ex t

---

### **⚠ WARNING**

***Opening the position transmitter in potentially explosive dust atmospheres will render the explosion protection unsafe.***

- *Do not open the enclosure cover of the position transmitter in potentially explosive dust atmospheres.*
- 

In equipment operated according to type of protection Ex t (protection by enclosure), circuits may be connected, interrupted or switched while energized only during installation, maintenance or repair.

- Certified cable glands and blanking plugs with appropriate type of protection with an IP rating  $\geq 66$  and suitable for the certified temperature range must be used.
- For Ex tb only use cables and cable glands which are suitable for the temperature range from –55 to +85 °C.

### **Connect the electrical supply**

1. Strip at least 8 mm insulation off the signal wires and guide them through the cable gland.
  2. Connect the signal wires to the screw terminals as shown in Fig. 5-8.
- Observe the correct polarity.

## Installation

---

**i Note**

The signal wires transmit the 4 to 20 mA measuring signal and the required voltage supply ( $U_B = 12$  to 36 V DC) for the two-wire transmitter.

---

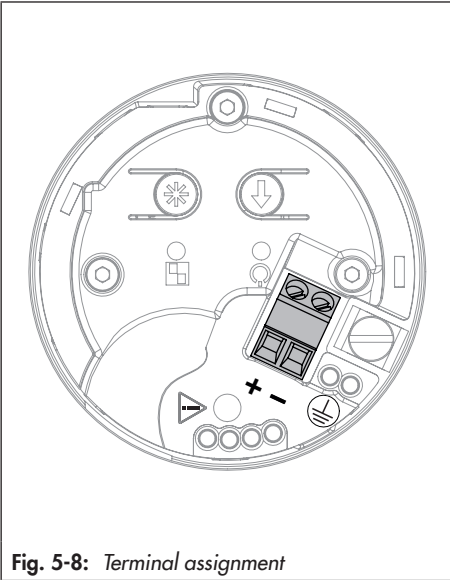

Fig. 5-8: Terminal assignment

## 5.8 Mounting accessories

**Table 5-1:** *General accessories*

Designation	Order no.
M20x1.5 Ex d cable gland, made of brass, with O-ring, for non-armored cable (6.5 to 14 mm cable diameter)	8808-0200
½ NPT Ex d cable gland, made of brass, with O-ring, for non-armored cable (6.5 to 14 mm cable diameter)	8808-2010
M20x1.5 Ex e cable gland, made of polyamide (black), with O-ring	8808-0178 <sup>1)</sup>
M20x1.5 cable gland, made of brass, with O-ring	1890-4875 <sup>1)</sup>
M20x1.5 cable gland, made of brass (blue), with O-ring	1890-4876 <sup>1)</sup>
M20x1.5 cable gland, made of polyamide (black), without O-ring	8808-1011 <sup>1)</sup>
M20x1.5 cable gland, made of polyamide (blue), without O-ring	8808-1012 <sup>1)</sup>
O-ring 18x2	8421-0067

<sup>1)</sup> The cable gland is not suitable for Ex d instrumentation.

**Table 5-2:** *Mounting kits*

Designation	Order no.
Attachment according to VDI/VDE 3845, level 2, heavy-duty version	1400-9974
Attachment according to VDI/VDE 3845, level 1, light version (AA1 to AA4 size)	1400-7473
Attachment according to VDI/VDE 3845, level 1, heavy-duty version (AA1 to AA4 size)	1400-9384
Attachment according to VDI/VDE 3845, level 1, heavy-duty version (AA5 size)	1400-9992
Attachment for VETEC S 160/R, heavy-duty version	1400-9385
Mounting kit for Type 3277 Linear Actuators (240, 350, 700 cm <sup>2</sup> )	1400-7471
Mounting kit for Type 3271 Linear Actuators (120 cm <sup>2</sup> )	1400-7472
Mounting kit for SED diaphragm valves (both mounting kits are required)	1402-1093 1400-7472
Mounting kit for control valves with NAMUR rib or attachment to valves with rod-type yokes according to IEC 60534-6 (20 to 35 mm rod diameter)	1400-7468
Mounting kit for Type 3510 Micro-flow Valve with 60 or 120 cm <sup>2</sup> actuator area	1400-7469





## 6 Operation

→ Fig. 6-1 shows the operating controls of the Type 4749 Position Transmitter.

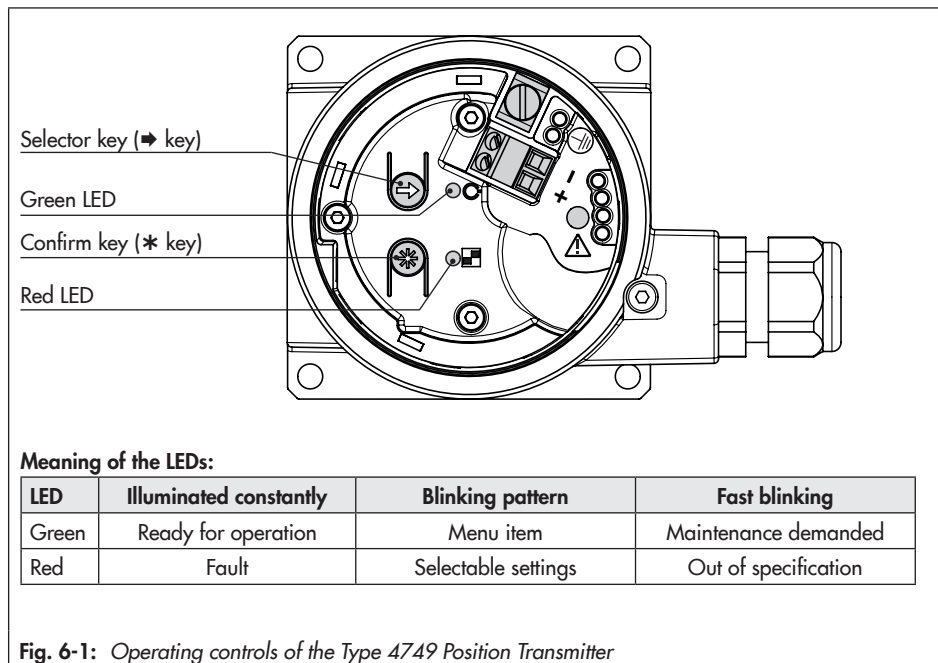

Fig. 6-1: Operating controls of the Type 4749 Position Transmitter

### 6.1 Operator keys and menu structure

After the power supply is connected, the green LED is illuminated constantly in the normal state (ready for operation).

Press ➔ key to open the menu level. Press ➔ key once to jump to the next item within the level. Press \* key to activate an item. Press ➔ key to select a function within this item. By pressing \* key, save or execute the selected function. The number of the menu item or function is indicated by a blinking pattern (see Table 6-1).

Keep ➔ key pressed and press \* key to leave a menu item without saving it or a function without executing it.

## Operation

**Table 6-1:** Menu structure

Item no., menu item/function	LED	Blinking pattern
0 Normal state	Green	Illuminated constantly
1 Enable configuration	Green	
Enable configuration	Red	
Lock configuration	Red	
2 Mounting	Green	
Linear actuator	Red	
Rotary actuator	Red	
3 Position at 4 mA	Green	
Save position	Red	
4 Position at 20 mA	Green	
Save position	Red	
5 Issue a test current	Green	
4 mA output	Red	
20 mA output	Red	
6 Reset to default settings	Green	
Execute reset	Red	

: Menu level   
  : Selection level

**i Note**

- If no keys are pressed within five minutes, the position transmitter returns to the normal state.
- When the selection level is activated, the device does not exit this level until a function or setting is made.

## 6.2 Locking the configuration

The configuration of the position transmitter can be locked. Afterwards, the menu items in the menu level cannot be opened. To lock configuration, proceed as follows:

1. Press **➔** key once to select menu item 1.

The green LED blinks according to the following pattern:



2. Press **\*** key to activate the selection level.

The red LED blinks according to the following pattern:

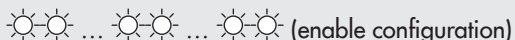

- ➔ Press **➔** key again. The red LED blinks according to the following pattern:

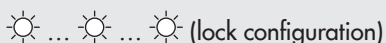

3. Press **\*** key to lock configuration.

The position transmitter returns to menu item 1.

The green LED blinks according to the following pattern:



- ➔ Press **➔** key to return to the normal state.

The green LED is constantly illuminated when the procedure is completed.



## 7 Start-up

The work described in this section is only to be performed by personnel appropriately qualified to carry out such tasks.

---

### DANGER

***Risk of fatal injury due to the ignition of an explosive atmosphere.***

- *Installation, operation or maintenance of the position transmitter must only be performed by personnel with qualifications according to Clause 4.5 of IEC 60079-14 who has undergone special training or instructions or who is authorized to work on explosion-protected devices in hazardous areas.*
- 

### DANGER

***Loss of the explosion protection due to damage to the cover's thread and/or the connecting thread.***

- *Do not open devices with flameproof enclosures while they are energized.*
- 

### WARNING

***Opening the position transmitter in potentially explosive dust atmospheres will render the explosion protection unsafe.***

- *Do not open the enclosure cover of the position transmitter in potentially explosive dust atmospheres.*
- 

### NOTICE

***Risk of malfunction due to calibration not being performed.***

- *Perform calibration before initial start-up.*
  - *Calibrate the position transmitter after changing the mounting position.*
-

### 7.1 Determining the mounting situation

The position transmitter can be mounted on linear or rotary actuators. The actuator mounting is determined in menu item 2.

1. Press **➡** key twice to select menu item 2.

The green LED blinks according to the following pattern:



2. Press **\*** key to activate the selection level.

The red LED blinks according to the following pattern:

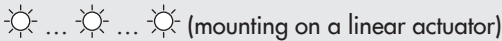

- ➔ Press **➡** key again. The red LED blinks according to the following pattern:

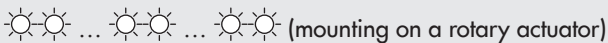

- ➔ Press **➡** key to switch between the two options.

3. Press **\*** key to save the required setting.

The position transmitter returns to menu item 2.

The green LED blinks according to the following pattern:

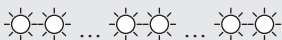

4. Press **➡** key five times to return to the normal state.

The green LED is constantly illuminated when the procedure is completed.

### 7.2 Determining the position at 4 mA

The first position is assigned to the 4 mA signal.

1. Press **➡** key three times to select menu item 3.

The green LED blinks according to the following pattern:



2. Press \* key to activate the selection level.

The red LED blinks according to the following pattern:



3. Press \* key again to assign the current position to the 4 mA signal.

The red LED illuminates for one second. The position transmitter returns to menu item 3.

The green LED blinks according to the following pattern:



4. Press ➔ key four times to return to the normal state.

The green LED is constantly illuminated when the procedure is completed.

## 7.2.1 Determining the position at 20 mA

The second position is assigned to the 20 mA signal.

1. Press ➔ key four times to select menu item 4.

The green LED blinks according to the following pattern:

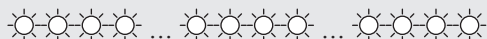

2. Press \* key to activate the selection level.

The red LED blinks according to the following pattern:



3. Press \* key again to assign the current position to the 20 mA signal.

The red LED illuminates for one second. The position transmitter returns to menu item 4.

The green LED blinks according to the following pattern:

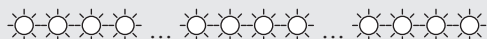

4. Press ➔ key three times to return to the normal state.

The green LED is constantly illuminated when the procedure is completed.

## 7.2.2 Issuing a test current

Independent from the position of the position transmitter, 4 or 20 mA test signals can be issued.

1. Press **➡** key five times to select menu item 5.

The green LED blinks according to the following pattern:



2. Press **\*** key to activate the selection level.

The red LED blinks according to the following pattern:



- ➔ Press **➡** key again. The red LED blinks according to the following pattern:



- ➔ Press **➡** key to switch between both signals.

3. Press **\*** key to return to menu item 5.

The red LED blinks according to the following pattern:



4. Press **➡** key twice to return to the normal state.

The green LED is constantly illuminated when the procedure is completed.



## 8 Operation

The work described in this section is only to be performed by personnel appropriately qualified to carry out such tasks.

---

### **⚠ DANGER**

***Risk of fatal injury due to the ignition of an explosive atmosphere.***

- *Installation, operation or maintenance of the position transmitter must only be performed by personnel with qualifications according to Clause 4.5 of IEC 60079-14 who has undergone special training or instructions or who is authorized to work on explosion-protected devices in hazardous areas.*
- 

### **⚠ DANGER**

***Loss of the explosion protection due to damage to the cover's thread and/or the connecting thread.***

- *Do not open devices with flameproof enclosures while they are energized.*
- 

### **⚠ WARNING**

***Opening the position transmitter in potentially explosive dust atmospheres will render the explosion protection unsafe.***

- *Do not open the enclosure cover of the position transmitter in potentially explosive dust atmospheres.*
- 

The position transmitter converts the linear or rotary motion of a control valve into a corresponding electric signal as soon as it is connected to the power supply.

- Put the control valve into operation by switching on the signal pressure and electrical supply.

## 8.1 Resetting the position transmitter to default settings

All settings of the position transmitter are reset to their default settings as follows:

1. Press **➔** key six times to select menu item 6.

The green LED blinks according to the following pattern:



2. Press **\*** key to activate the selection level.

The red LED blinks according to the following pattern:



3. Press **\*** key again to perform the reset function.

The red LED illuminates briefly. The position transmitter returns to menu item 6.

The green LED blinks according to the following pattern:



4. Press **➔** key to return to the normal state.

The green LED is constantly illuminated when the procedure is completed.

## 9 Malfunctions

The work described in this section is only to be performed by personnel appropriately qualified to carry out such tasks.

The LEDs illuminate constantly or blink (see Table 9-1) to indicate a malfunction.

### **⚠ DANGER**

**Risk of fatal injury due to the ignition of an explosive atmosphere.**

- ➔ Installation, operation or maintenance of the position transmitter must only be performed by personnel with qualifications according to Clause 4.5 of IEC 60079-14 who has undergone special training or instructions or who is authorized to work on explosion-protected devices in hazardous areas.

### **⚠ DANGER**

**Loss of the explosion protection due to damage to the cover's thread and/or the connecting thread.**

- ➔ Do not open devices with flameproof enclosures while they are energized.

### **⚠ WARNING**

**Opening the position transmitter in potentially explosive dust atmospheres will render the explosion protection unsafe.**

- ➔ Do not open the enclosure cover of the position transmitter in potentially explosive dust atmospheres.

### **⚠ WARNING**

**Crush hazard arising from moving parts on the valve and actuator.**

- ➔ Before performing any mounting or installation work on the position transmitter, put the control valve out of operation by disconnecting and locking the supply and control signal.

## 9.1 Troubleshooting

See Table 9-1

## 9.2 Emergency action

The plant operator is responsible for emergency action to be taken in the plant.

### **💡 Tip**

Emergency action in the event of valve failure is described in the associated valve documentation.

## Malfunions

**Table 9-1:** Error messages

<b>Reading: green LED blinks</b>	
Error status	Maintenance demanded
Cause	– Internal pulse generator (crystal oscillator) has failed.
Impact	– Output rate of 1 ms cannot be maintained. – The device continues to run at a slower output rate.
Recommended action	→ Replace the device during the next service routine. → Contact SAMSON's After-sales Service.
<b>Reading: red LED blinks</b>	
Error status	Out of specification
Cause	– Temperature limits have been exceeded. – Adjusted measuring range is too small (span error).
Impact	– Position measurement is not possible. – The residual current $I \leq 3.6$ mA is issued at the output.
Recommended action	→ Run the device within specification (see technical data in the 'Design and principle of operation' section). → Check positioner attachment, lever and pin position (see the 'Installation' section). → Check the control valve to ensure it functions properly. → Check power supply/electrical signal. → Adjust zero and span (see the 'Start-up' section).
<b>Reading: red LED illuminated</b>	
Error status	Failure
Cause	– Defect in the electronics or memory error – The device is not running within specification
Impact	– Position measurement is not possible. – The residual current $I \leq 3.6$ mA is issued at the output.
Recommended action	→ Press * key to reset. → Contact SAMSON's After-sales Service if the error message reoccurs.

## 10 Servicing

The work described in this section is only to be performed by personnel appropriately qualified to carry out such tasks.

### **⚠ DANGER**

**Risk of fatal injury due to the ignition of an explosive atmosphere.**

- Installation, operation or maintenance of the position transmitter must only be performed by personnel with qualifications according to Clause 4.5 of IEC 60079-14 who has undergone special training or instructions or who is authorized to work on explosion-protected devices in hazardous areas.

### **⚠ DANGER**

**Loss of the explosion protection due to damage to the cover's thread and/or the connecting thread.**

- Do not open devices with flameproof enclosures while they are energized.

### **⚠ WARNING**

**Opening the position transmitter in potentially explosive dust atmospheres will render the explosion protection unsafe.**

- Do not open the enclosure cover of the position transmitter in potentially explosive dust atmospheres.

### **⚠ WARNING**

**Crush hazard arising from moving parts on the valve and actuator.**

- Before performing any mounting or installation work on the position transmitter, put the control valve out of operation by disconnecting and locking the supply and control signal.

### **i Note**

The position transmitter was checked by SAMSON before it left the factory.

- The product warranty becomes void if service or repair work not described in these instructions is performed without prior agreement by SAMSON's After-sales Service.
- Only use original spare parts by SAMSON, which comply with the original specifications.

## 10.1 Periodic inspection and testing of the position transmitter

We recommend inspection and testing according to Table 10-1 at the minimum.

**Table 10-1:** *Recommended inspection and testing*

Inspection and testing	Action to be taken in the event of a negative result
Check the markings, labels and nameplates on the position transmitter for their readability and completeness.	Contact SAMSON when nameplates or labels are damaged, missing or incorrect to renew them.
	Clean any inscriptions that are covered with dirt and are illegible.
Check the position transmitter to ensure it is mounted properly.	Tighten the any loose mounting screws.
Check the power lines.	Tighten any loose cable glands.
	Make sure that the stranded wires are pushed into the terminals and tighten any loose screws on the the terminals.
	Renew damaged lines.
Check whether errors or faults are indicated by the LEDs.	Troubleshooting (see the 'Malfunctions' section).

## 11 Decommissioning

---

### **⚠ DANGER**

***Risk of fatal injury due to the ignition of an explosive atmosphere.***

- *For mounting and electrical installation in hazardous areas, observe the explosion protection approvals as well as the relevant electrotechnical regulations and the accident prevention regulations that apply in the country of use. EN 60079-14 applies in Europe.*
  - *Installation, operation or maintenance of the position transmitter must only be performed by personnel with qualifications according to Clause 4.5 of IEC 60079-14 who has undergone special training or instructions or who is authorized to work on explosion-protected devices in hazardous areas.*
- 

### **⚠ DANGER**

***Loss of the explosion protection due to damage to the cover's thread and/or the connecting thread.***

- *Do not open devices with flameproof enclosures while they are energized.*
- 

### **⚠ WARNING**

***Opening the position transmitter in potentially explosive dust atmospheres will render the explosion protection unsafe.***

- *Do not open the enclosure cover of the position transmitter in potentially explosive dust atmospheres.*
- 

To decommission the position transmitter before removing it, proceed as follows:

1. Put the control valve out of operation by disconnecting and locking the supply and control signal.
2. Open the enclosure cover of the position transmitter.
3. Disconnect the lines for the power supply.





## 12 Removal

The work described in this section is only to be performed by personnel appropriately qualified to carry out such tasks.

---

### DANGER

***Risk of fatal injury due to the ignition of an explosive atmosphere.***

- *For mounting and electrical installation in hazardous areas, observe the explosion protection approvals as well as the relevant electrotechnical regulations and the accident prevention regulations that apply in the country of use. EN 60079-14 applies in Europe.*
  - *Installation, operation or maintenance of the position transmitter must only be performed by personnel with qualifications according to Clause 4.5 of IEC 60079-14 who has undergone special training or instructions or who is authorized to work on explosion-protected devices in hazardous areas.*
- 

1. Put the position transmitter out of operation (see the 'Decommissioning' section).
2. Disconnect the wires for the power supply from the position transmitter.
3. To remove the position transmitter, loosen the four fastening screws on the device.



## 13 Repairs

A defective position transmitter must be repaired or replaced.

### ! NOTICE

**Risk of damage to the position transmitter due to incorrect repair work.**

- Do not perform any repair work on your own.
- Contact SAMSON's After-sales Service for repair work.

### 13.1 Servicing explosion-protected devices

If a part of the device on which the explosion protection is based needs to be serviced, the device must not be put back into operation until a qualified inspector has assessed it according to explosion protection requirements, has issued an inspection certificate or given the device a mark of conformity. Inspection by a qualified inspector is not required if the manufacturer performs a routine test on the device before putting it back into operation and the passing of the routine test is documented by attaching a mark of conformity to the device.

Inspection by a qualified inspector is not required if the manufacturer performs a routine test on the device before putting it back into operation and the passing of the routine test is documented by attaching a mark of conformity to the device.

- Retain testing and servicing documents as well as certificates issued by the manufacturer or inspector together with other safety-relevant documents for the device or plant.

Replace explosion-protected components only with original, routine-tested components by the manufacturer.

Devices that have already been operated outside hazardous areas and are intended for future use inside hazardous areas must comply with the safety requirements placed on serviced devices. Before being operated inside hazardous areas, test the devices according to the specifications for servicing explosion-protected devices.

#### Repair of flameproof gaps

A repair of flameproof gaps is not permitted. If a corresponding gap is damaged, the device must be replaced.

#### Maintenance, calibration and work on equipment

Observe the maximum permissible values specified in the certificates for intrinsically safe circuits to ensure that components relevant to explosion protection are not damaged.

### 13.2 Returning devices to SAMSON

Defective position transmitters can be returned to SAMSON for repair.

Proceed as follows to return devices to SAMSON:

1. Put the position transmitter out of operation (see the 'Decommissioning' section).
2. Remove the position transmitter (see the 'Removal' section).
3. Proceed as described on the Returning goods page of our website  
▶ [www.samsongroup.com](http://www.samsongroup.com) > Service & Support > After-sales Service > Returning goods

## 14 Disposal



We are registered with the German national register for waste electric equipment (stiftung ear) as a producer of electrical and electronic equipment, WEEE reg. no.: DE 62194439

- Observe local, national and international refuse regulations.
- Do not dispose of components, lubricants and hazardous substances together with your other household waste.

**Tip**

*On request, we can appoint a service provider to dismantle and recycle the product.*

---



## 15 Certificates

The following certificates are included on the next pages:

- EU declaration of conformity for Type 4749
- EU declaration of conformity for Type 4749-111
- EU declaration of conformity for Type 4749-180
- EU declaration of conformity for Type 4749-210
- EU type examination certificate for Type 4749-110
- EU type examination certificate for Type 4749-180
- EU type examination certificate for Type 4749-210
- IECEx certificate for Type 4749-111
- IECEx certificate for Type 4749-181
- IECEx certificate for Type 4749-211

The certificates shown were up to date at the time of publishing. The latest certificates can be found on our website:

► [www.samsongroup.com](http://www.samsongroup.com) > Products & Applications > Product selector > Valve accessories > Type 4749



## EU Konformitätserklärung / EU Declaration of Conformity / Déclaration UE de conformité

Die alleinige Verantwortung für die Ausstellung dieser Konformitätserklärung trägt der Hersteller/  
This declaration of conformity is issued under the sole responsibility of the manufacturer/  
La présente déclaration de conformité est établie sous la seule responsabilité du fabricant.  
Für das folgende Produkt / For the following product / Nous certifions que le produit

### Stellungsmelder / Position Transmitter / Recopieur de position Typ/Type/Type 4749

wird die Konformität mit den einschlägigen Harmonisierungsrechtsvorschriften der Union bestätigt/  
the conformity with the relevant Union harmonisation legislation is declared with/  
est conforme à la législation d'harmonisation de l'Union applicable selon les normes:

EMC 2014/30/EU

EN 61000-6-2:2005, EN 61000-6-3:2007  
+A1:2011, EN 61326-1:2013

RoHS 2011/65/EU

EN 50581:2012

Hersteller / Manufacturer / Fabricant:

SAMSON AKTIENGESELLSCHAFT  
Weismüllerstraße 3  
D-60314 Frankfurt am Main  
Deutschland/Germany/Allemagne

Frankfurt / Francfort, 2018-11-26

Im Namen des Herstellers/ On behalf of the Manufacturer/ Au nom du fabricant.

Dr. Julian Fuchs  
Zentralabteilungsleiter/Head of Department/Chef du département  
Entwicklung Ventilanbaugeräte und Messtechnik  
Development Valve Attachments and Measurement Technologies

Dipl.-Ing. Silke Bianca Schäfer  
Total Quality Management/  
Management par la qualité totale

ce\_4749-0\_de\_en\_fr\_rev08.pdf





## EU Konformitätserklärung / EU Declaration of Conformity / Déclaration UE de conformité

Die alleinige Verantwortung für die Ausstellung dieser Konformitätserklärung trägt der Hersteller/  
This declaration of conformity is issued under the sole responsibility of the manufacturer/  
La présente déclaration de conformité est établie sous la seule responsabilité du fabricant.  
Für das folgende Produkt / For the following product / Nous certifions que le produit

### Stellungsmelder / Position Transmitter / Recopieur de position Typ/Type/Type 4749-110

entsprechend der EU-Baumusterprüfbescheinigung KIWA 18ATEX0031 X ausgestellt von der/  
according to the EU Type Examination KIWA 18ATEX0031 X issued by/  
établi selon le certificat CE d'essais sur échantillons KIWA 18ATEX0031 X émis par:

KIWA Nederland B.V.  
Sir Winston Churchill-laan 273  
2288 EA Rijswijk  
Postbus 70 2280 AB Rijswijk  
Benannte Stelle/Notified Body/Organisme notifié 0620

wird die Konformität mit den einschlägigen Harmonisierungsrechtsvorschriften der Union bestätigt /  
the conformity with the relevant Union harmonisation legislation is declared with/  
est conforme à la législation d'harmonisation de l'Union applicable selon les normes:

EMC 2014/30/EU	EN 61000-6-2:2005, EN 61000-6-3:2007 +A1:2011, EN 61326-1:2013
Explosion Protection 2014/34/EU	EN 60079-0: 2012 + A11: 2013, EN 60079-11: 2012
RoHS 2011/65/EU	EN 50581:2012

Hersteller / Manufacturer / Fabricant:

SAMSON AKTIENGESELLSCHAFT  
Weismüllerstraße 3  
D-60314 Frankfurt am Main  
Deutschland/Germany/Allemagne

Frankfurt / Francfort, 2019-02-13

Im Namen des Herstellers/ On behalf of the Manufacturer/ Au nom du fabricant.

Dr. Julian Fuchs  
Zentralabteilungsleiter/Head of Department/Chef du département  
Entwicklung Ventilanbaugeräte und Messtechnik  
Development Valve Attachments and Measurement Technologies

Dipl.-Ing. Silke Bianca Schäfer  
Total Quality Management/  
Management par la qualité totale

ce\_4749-110\_de\_en\_fo\_rev08.pdf



## EU Konformitätserklärung / EU Declaration of Conformity / Déclaration UE de conformité

Die alleinige Verantwortung für die Ausstellung dieser Konformitätserklärung trägt der Hersteller/  
This declaration of conformity is issued under the sole responsibility of the manufacturer/  
La présente déclaration de conformité est établie sous la seule responsabilité du fabricant.  
Für das folgende Produkt / For the following product / Nous certifions que le produit

### Stellungsmelder / Position Transmitter / Recopieur de position Typ/Type/Type 4749-180

entsprechend der EU-Baumusterprüfbescheinigung KIWA 19ATEX0038 X ausgestellt von der/  
according to the EU Type Examination KIWA 19ATEX0038 X issued by/  
établi selon le certificat CE d'essais sur échantillons KIWA 19ATEX0038 X émis par:

KIWA Nederland B.V.  
Wilmersdorf 50  
P.O. Box 137  
7300 AC Apeldoorn

Benannte Stelle/Notified Body/Organisme notifié 0620

wird die Konformität mit den einschlägigen Harmonisierungsrechtsvorschriften der Union bestätigt /  
the conformity with the relevant Union harmonisation legislation is declared with/  
est conforme à la législation d'harmonisation de l'Union applicable selon les normes:

EMC 2014/30/EU	EN 61000-6-2:2019, EN 61000-6-3:2007 +A1:2011, EN 61326-1:2013
Explosion Protection 2014/34/EU	EN 60079-0:2018, EN 60079-1:2014, EN 60079-11:2012, EN 60079-31:2014
RoHS 2011/65/EU	EN 50581:2012

Hersteller / Manufacturer / Fabricant:

SAMSON AKTIENGESELLSCHAFT  
Weismüllerstraße 3  
D-60314 Frankfurt am Main  
Deutschland/Germany/Allemagne

Frankfurt / Francfort, 2019-11-29

Im Namen des Herstellers/ On behalf of the Manufacturer/ Au nom du fabricant.

Dipl.-Ing. Jens Bieger  
Zentralabteilungsleiter/Head of Department/Chef de département  
Entwicklung Ventilanbaugeräte und Messtechnik  
Development Valve Attachments and Measurement Technologies

Dipl.-Ing. Silke Bianca Schäfer  
Total Quality Management/  
Management par la qualité totale



## EU Konformitätserklärung / EU Declaration of Conformity / Déclaration UE de conformité

Die alleinige Verantwortung für die Ausstellung dieser Konformitätserklärung trägt der Hersteller/  
This declaration of conformity is issued under the sole responsibility of the manufacturer/  
La présente déclaration de conformité est établie sous la seule responsabilité du fabricant.  
Für das folgende Produkt / For the following product / Nous certifions que le produit

### Stellungsmelder / Position Transmitter / Recopieur de position Typ/Type/Type 4749-210

entsprechend der EU-Baumusterprüfbescheinigung KIWA 18ATEX0036 X ausgestellt von der/  
according to the EU Type Examination KIWA 18ATEX0036 X issued by/  
établi selon le certificat CE d'essais sur échantillons KIWA 18ATEX0036 X émis par:

KIWA Nederland B.V.  
Sir Winston Churchill-laan 273  
2288 EA Rijswijk  
Postbus 70 2280 AB Rijswijk  
Benannte Stelle/Notified Body/Organisme notifié 0620

wird die Konformität mit den einschlägigen Harmonisierungsrechtsvorschriften der Union bestätigt /  
the conformity with the relevant Union harmonisation legislation is declared with/  
est conforme à la législation d'harmonisation de l'Union applicable selon les normes:

EMC 2014/30/EU	EN 61000-6-2:2005, EN 61000-6-3:2007 +A1:2011, EN 61326-1:2013
Explosion Protection 2014/34/EU	EN 60079-0: 2012 + A11: 2013, EN 60079-1: 2014, EN 60079-31: 2014
RoHS 2011/65/EU	EN 50581:2012

Hersteller / Manufacturer / Fabricant:

SAMSON AKTIENGESELLSCHAFT  
Weismüllerstraße 3  
D-60314 Frankfurt am Main  
Deutschland/Germany/Allemagne

Frankfurt / Francfort, 2018-11-26

Im Namen des Herstellers/ On behalf of the Manufacturer/ Au nom du fabricant.

Dr. Julian Fuchs  
Zentralabteilungsleiter/Head of Department/Chef du département  
Entwicklung Ventilbaugeräte und Messtechnik  
Development Valve Attachments and Measurement Technologies

Dipl.-Ing. Silke Bianca Schäfer  
Total Quality Management/  
Management par la qualité totale



## 1 EU – Type Examination Certificate

2 Equipment or Protective System Intended for use in Potentially Explosive Atmospheres  
**Directive 2014/34/EU**

3 EU – Type Examination Certificate Number: **KIWA 18ATEX0031 X Issue: 1**

4 Product: **Position Transmitter Type 4749**

5 Manufacturer: **SAMSON AKTIENGESELLSCHAFT**

6 Address: **Weismüllerstraße 3, 60314 Frankfurt  
Germany**

7 This product and any acceptable variation thereto is specified in the schedule to this certificate and the documents therein referred to.

8 Kiwa Nederland B.V., Notified Body number 0620 in accordance with Article 17 of Directive 2014/34/EU of the European Parliament and of the Council, dated 26 February 2014, certifies that this product has been found to comply with the Essential Health and Safety Requirements relating to the design and construction of products intended for use in potentially explosive atmospheres given in Annex II to the Directive.  
The examination and test results are recorded in confidential ATEX Assessment Report No. 180600585.

9 Compliance with the Essential Health and Safety Requirements has been assured by compliance with:  
**EN 60079-0 : 2012 + A11 : 2013 EN 60079-11 : 2012**

10 If the sign "X" is placed after the certificate number, it indicates that the product is subject to the Specific Conditions of Use specified in the schedule to this certificate.

11 This EU – Type Examination Certificate relates only to the design and construction of the specified product. Further requirements of the Directive apply to the manufacturing process and supply of this product. These are not covered by this certificate.

12 The marking of the product shall include the following:



II 2 G

II 2 D

Ex ia IIC T6...T4 Gb

Ex ia IIIC T85 °C Db

Kiwa Nederland B.V.  
Unit Kiwa ExVision  
Wilmsdorf 50  
P.O. Box 137  
7300 AC Apeldoorn  
The Netherlands

Tel. +31 89 998 34 93  
Fax +31 89 998 36 95  
ExVision@kiwa.nl  
www.kiwaexvision.com

Kiwa Nederland B.V.

*Pieter van Breugel*  
Pieter van Breugel  
Certification Officer

Issue date:

9 January 2019

First Issue:

---

This certificate shall, as far as applicable, be revised before the date of cessation of presumption of conformity of (one of) the included standards above as communicated in the Official Journal of the European Union.

© Integral publication of this certificate in its entirety and without any change is allowed.



13 **SCHEDULE**

14 **EU – Type Examination Certificate KIWA 18ATEX0031 X Issue No. 1**

15.1 **Description of Product**

The Position Transmitter Type 4749 is mounted on control valves and converts the lifting or rotating movements of the valve drive into a 4-20 mA current signal.

The position transmitter enclosure is provided with a threaded cover and can be of aluminium or stainless steel.

Maximum ambient temperature for T6 and T85 °C: +55 °C

Maximum ambient temperature for T5: +70 °C

Maximum ambient temperature for T4: +80 °C

Minimum ambient temperature: -40 °C

The Position Transmitter enclosure provides a degree of protection of IP66 in accordance with EN 60529.

Type designation

4749-abcde

a: Approvals

110 (Intrinsically safe ATEX)

b: Options

0 (position transmitter 4 - 20 mA)

c: Reserved

X (not safety relevant)

d: Field wiring entry

0 (M20x1,5)

1 (NPT 1/2")

e: Enclosure material

0 (aluminium)

1 (stainless steel)

15.2 **Electrical Data**

Supply and output circuit (terminals +31, -32):

in type of protection intrinsic safety Ex ia IIC, only for connection to a certified intrinsically safe circuit, with the following maximum values:

Ui = 28 V; Ii = 115 mA; Pi = 1,0 W; Ci = 19,2 nF; Li = 0 mH

15.3 **Instructions**

The instructions provided with the product shall be followed in detail to assure safe operation.

16 **ATEX Assessment Report Number**

180600585.

13 **SCHEDULE**

14 **EU – Type Examination Certificate KIWA 18ATEX0031 X Issue No. 1**

17 **Specific Conditions of Use**

For the applicable ambient temperature range, refer to 15.

For EPL Db:

- The equipment shall be installed and maintained such that hazards caused by electrostatic discharge are excluded;
- Heat resisting cables and cable glands, suitable for a temperature of at least 20 K higher than the max. ambient temperature shall be used.

18 **Essential Health and Safety Requirements**

All relevant Essential Health and Safety Requirements are covered by the standards listed at section 9.

19 **Drawings and Documents**

As listed in ATEX Assessment Report No. 180600585.





# CERTIFICATE

## 1 EU – Type Examination Certificate

2 Equipment or Protective System Intended for use in Potentially Explosive Atmospheres  
**Directive 2014/34/EU**

3 EU – Type Examination Certificate Number: **KIWA 19ATEX0038 X Issue: 1**

4 Product: **Position Transmitter Type 4749**

5 Manufacturer: **SAMSON AKTIENGESELLSCHAFT**

6 Address: **Weismüllerstraße 3, 60314 Frankfurt  
Germany**

7 This product and any acceptable variation thereto is specified in the schedule to this certificate and the documents therein referred to.

8 Kiwa Nederland B.V., Notified Body number 0620 in accordance with Article 17 of Directive 2014/34/EU of the European Parliament and of the Council, dated 26 February 2014, certifies that this product has been found to comply with the Essential Health and Safety Requirements relating to the design and construction of products intended for use in potentially explosive atmospheres given in Annex II to the Directive.  
The examination and test results are recorded in confidential ATEX Assessment Report No. 190701457.

9 Compliance with the Essential Health and Safety Requirements has been assured by compliance with:  
**EN 60079-0 : 2012 + A11 : 2013 EN 60079-1 : 2014 EN 60079-11 : 2012  
EN 60079-31 : 2014**

10 If the sign "X" is placed after the certificate number, it indicates that the product is subject to the Specific Conditions of Use specified in the schedule to this certificate.

11 This EU – Type Examination Certificate relates only to the design and construction of the specified product. Further requirements of the Directive apply to the manufacturing process and supply of this product. These are not covered by this certificate.

12 The marking of the product shall include the following:



II 2 G Ex ia IIC T6...T4 Gb  
II 2 D Ex ia IIIC T85 °C Db  
or  
II 2 G Ex db IIC T6...T4 Gb  
II 2 D Ex tb IIIC T80 °C Db

Kiwa Nederland B.V.  
Unit Kiwa EXVision  
Wilmsdorff 50  
P.O. Box 137  
7300 AC Apeldoorn  
The Netherlands

Tel. +31 88 998 34 93  
Fax +31 88 998 36 85  
EXVision@kiwa.nl  
www.kiwaevision.com

Kiwa Nederland B.V.

Issue date:

10 October 2019

First issue:

---

Ronald Karel

Managing Director

This certificate shall, as far as applicable, be revised before the date of cessation of presumption of conformity of (one of) the included standards above as communicated in the Official Journal of the European Union.

© Integral publication of this certificate in its entirety and without any change is allowed.

ExVision Form 81  
Version 3.1 (2019-01)



Page 1 of 3

## 13 SCHEDULE

### 14 EU – Type Examination Certificate KIWA 19ATEX0038 X Issue No. 1

#### 15.1 Description of Product

The Position Transmitter Type 4749 is mounted on control valves and converts the lifting or rotating movements of the valve drive into a 4-20 mA current signal.

The position transmitter enclosure is provided with a threaded cover and can be of aluminum or stainless steel.

Type of protection	T-class	Ambient temperature range
Ex ia IIC	T6	-40 °C to +55 °C
	T5	-40 °C to +70 °C
	T4	-40 °C to +80 °C
Ex ia IIIC	T85 °C	-40 °C to +55 °C
Ex db IIC	T6	-55 °C to +65 °C
	T5	-55 °C to +80 °C
	T4	-55 °C to +85 °C
Ex tb IIIC	T80 °C	-55 °C to +65 °C

The Position Transmitter enclosure provides a degree of protection of IP66 in accordance with EN 60529.

Type designation

4749-abcde

- a: Approvals  
180 (Intrinsically safe / Explosion proof ATEX)
- b: Options  
0 (position transmitter 4 - 20 mA)
- c: Reserved  
X (not safety relevant)
- d: Field wiring entry  
0 (M20x1,5)  
1 (NPT 1/2")
- e: Enclosure material  
0 (aluminium)  
1 (stainless steel)

#### 15.2 Electrical Data

Type of protection db or tb:  
Power supply: 12-28 Vdc, 4-20 mA.

Type of protection ia:  
Supply and output circuit (terminals +31, -32):  
in type of protection intrinsic safety Ex ia IIC, only for connection to a certified intrinsically safe circuit, with the following maximum values:  
Ui = 28 V; Ii = 115 mA; Pi = 1,0 W; Ci = 19,2 nF; Li = 0 mH



13 **SCHEDULE**

14 **EU – Type Examination Certificate KIWA 19ATEX0038 X Issue No. 1**

15.3 **Instructions**

The instructions provided with the product shall be followed in detail to assure safe operation.

16 **ATEX Assessment Report Number**

190701457.

17 **Specific Conditions of Use**

- For the applicable ambient temperature range, refer to the Equipment section above;
- For Type of protection Ex db: The flameproof joints are not intended to be repaired;
- For Type of protection Ex tb and Ex ia IIIC: The equipment shall be installed and maintained such that hazards caused by electrostatic discharge are excluded;
- For Type of protection Ex db, Ex tb and Ex ia IIIC: Heat resisting cables and cable glands, suitable for a temperature of at least 20 K higher than the max. ambient temperature shall be used.

18 **Essential Health and Safety Requirements**

All relevant Essential Health and Safety Requirements are covered by the standards listed at section 9.

19 **Drawings and Documents**

As listed in ATEX Assessment Report No. 190701457.



# CERTIFICATE

## 1 EU – Type Examination Certificate

2 Equipment or Protective System Intended for use in Potentially Explosive Atmospheres  
Directive 2014/34/EU

3 EU – Type Examination Certificate Number: KIWA 18ATEX0036 X Issue: 1

4 Product: Position Transmitter Type 4749

5 Manufacturer: SAMSON AKTIENGESELLSCHAFT

6 Address: Weismüllerstraße 3, 60314 Frankfurt  
Germany

7 This product and any acceptable variation thereto is specified in the schedule to this certificate and the documents therein referred to.

8 Kiwa Nederland B.V., Notified Body number 0620 in accordance with Article 17 of Directive 2014/34/EU of the European Parliament and of the Council, dated 26 February 2014, certifies that this product has been found to comply with the Essential Health and Safety Requirements relating to the design and construction of products intended for use in potentially explosive atmospheres given in Annex II to the Directive.  
The examination and test results are recorded in confidential ATEX Assessment Report No. 181000869.

9 Compliance with the Essential Health and Safety Requirements has been assured by compliance with:

EN 60079-0 : 2012 + A11 : 2013 EN 60079-1 : 2014 EN 60079-31 : 2014

10 If the sign "X" is placed after the certificate number, it indicates that the product is subject to the Specific Conditions of Use specified in the schedule to this certificate.

11 This EU – Type Examination Certificate relates only to the design and construction of the specified product. Further requirements of the Directive apply to the manufacturing process and supply of this product. These are not covered by this certificate.

12 The marking of the product shall include the following:



II 2 G Ex db IIC T6...T4 Gb  
II 2 D Ex tb IIIC T80 °C Db

Kiwa Nederland B.V.  
Unit Kiwa ExVision  
Wilmersdorf 50  
P.O. Box 137  
7300 AC Apeldoorn  
The Netherlands

Tel. +31 88 998 34 93  
Fax +31 88 998 36 85  
ExVision@kiwa.nl  
www.kiwaexvision.com

Kiwa Nederland B.V.

Pieter van Breugel  
Certification Officer

Issue date:

11 November 2018

First issue:

---

This certificate shall, as far as applicable, be revised before the date of cessation of presumption of conformity of (one of) the included standards above as communicated in the Official Journal of the European Union.

© Integral publication of this certificate in its entirety and without any change is allowed.

ExVision Form 81  
Version 3.0 (2018-06)



Page 1 of 3

13 **SCHEDULE**

14 **EU – Type Examination Certificate KIWA 18ATEX0036 X Issue No. 1**

15.1 **Description of Product**

The Position Transmitter Type 4749 is mounted on control valves and converts the lifting or rotating movements of the valve drive into a 4-20 mA current signal.

The position transmitter enclosure is provided with a threaded cover and can be of aluminium or stainless steel.

Ambient temperature range for Ex tb: -55 °C to +65 °C  
Ambient temperature range for Ex d: -55 °C to +65 °C for T6  
-55 °C to +80 °C for T5  
-55 °C to +85 °C for T4

The position transmitter enclosure provides a degree of protection of IP66 in accordance with EN 60529.

Type designation

4749-abcde

- a: Approvals  
210 (Explosion proof ATEX)
- b: Options  
0 (position transmitter 4-20 mA)
- c: Reserved  
X (not safety relevant)
- d: Field wiring entry  
0 (M20x1,5)  
1 (NPT 1/2")
- e: Enclosure material  
0 (aluminium)  
1 (stainless steel)

15.2 **Electrical Data**

Power supply: 12-28 Vdc, 4-20 mA

15.3 **Instructions**

The instructions provided with the product shall be followed in detail to assure safe operation.

16 **ATEX Assessment Report Number**

No. 181000869.



13 **SCHEDULE**

14 **EU – Type Examination Certificate KIWA 18ATEX0036 X Issue No. 1**

17 **Specific Conditions of Use**

- For the applicable ambient temperature range, refer to section 15.1;
- The flameproof joints are not intended to be repaired;
- For EPL Db: The equipment shall be installed and maintained such that hazards caused by electrostatic discharge are excluded;
- Heat resisting cables and cable glands, suitable for a temperature of at least 20 K higher than the max. ambient temperature shall be used.

18 **Essential Health and Safety Requirements**

All relevant Essential Health and Safety Requirements are covered by the standards listed at section 9.

19 **Drawings and Documents**

As listed in ATEX Assessment Report No. 181000869.



# IECEx Certificate of Conformity

## INTERNATIONAL ELECTROTECHNICAL COMMISSION IEC Certification Scheme for Explosive Atmospheres

for rules and details of the IECEx Scheme visit [www.iecex.com](http://www.iecex.com)

Certificate No.: IECEx KIWA 18.0014X Issue No: 0 Certificate history:  
Issue No. 0 (2019-01-09)

Status: Current Page 1 of 4

Date of Issue: 2019-01-09

Applicant: SAMSON AKTIENGESELLSCHAFT  
Weismüllerstraße 3  
60314 Frankfurt  
Germany

Equipment: Position Transmitter, Type 4749

Optional accessory:

Type of Protection: Ex Ia

Marking: Ex Ia IIC T6...T4 Gb  
Ex Ia IIIC T85 °C Db

Approved for issue on behalf of the IECEx  
Certification Body:

Pieter van Breugel

Position:

Certification Officer

Signature:  
(for printed version)

  
9<sup>th</sup> of January

Date:

1. This certificate and schedule may only be reproduced in full.
2. This certificate is not transferable and remains the property of the issuing body.
3. The Status and authenticity of this certificate may be verified by visiting the [Official IECEx Website](http://www.iecex.com).

Certificate issued by:

Kiwa Nederland B.V. (Unit Kiwa ExVision)  
Wilmersdorf 50  
7327 AC Apeldoorn  
P.O. Box 137  
The Netherlands





# IECEX Certificate of Conformity

Certificate No: IECEX KIWA 18.0014X Issue No: 0  
Date of Issue: 2019-01-09 Page 2 of 4  
Manufacturer: SAMSON AKTIENGESELLSCHAFT  
Weismüllerstraße 3  
60314 Frankfurt  
Germany

Additional Manufacturing location(s):

This certificate is issued as verification that a sample(s), representative of production, was assessed and tested and found to comply with the IEC Standard list below and that the manufacturer's quality system, relating to the Ex products covered by this certificate, was assessed and found to comply with the IECEx Quality system requirements. This certificate is granted subject to the conditions as set out in IECEx Scheme Rules, IECEx 02 and Operational Documents as amended.

#### STANDARDS:

The apparatus and any acceptable variations to it specified in the schedule of this certificate and the identified documents, was found to comply with the following standards:

IEC 60079-0 : 2011 Explosive atmospheres - Part 0: General requirements  
Edition:6.0  
IEC 60079-11 : 2011 Explosive atmospheres - Part 11: Equipment protection by intrinsic safety "I"  
Edition:6.0

*This Certificate does not indicate compliance with electrical safety and performance requirements other than those expressly included in the Standards listed above.*

#### TEST & ASSESSMENT REPORTS:

*A sample(s) of the equipment listed has successfully met the examination and test requirements as recorded in*

#### Test Report:

[NL/KIWA/ExTR18.0017/00](#)

#### Quality Assessment Report:

[DE/TUN/QAR06.0011/08](#)



# IECEX Certificate of Conformity

Certificate No: IECEX KIWA 18.0014X

Issue No: 0

Date of Issue: 2019-01-09

Page 3 of 4

## Schedule

### EQUIPMENT:

*Equipment and systems covered by this certificate are as follows:*

The Position Transmitter Type 4749 is mounted on control valves and converts the lifting or rotating movements of the valve drive into a 4-20 mA current signal.

The position transmitter enclosure is provided with a threaded cover and can be of aluminium or stainless steel.

Maximum ambient temperature for T6 and T85 °C: +55 °C

Maximum ambient temperature for T5: +70 °C

Maximum ambient temperature for T4: +80 °C

Minimum ambient temperature: -40 °C

The Position Transmitter enclosure provides a degree of protection of IP66 in accordance with IEC 60529.

### Type designation

4749-abcde

#### a: Approvals

111 (Intrinsically safe IECEx)

#### b: Options

0 (position transmitter 4 - 20 mA)

#### c: Reserved

X (not safety relevant)

#### d: Field wiring entry

0 (M20x1,5)

1 (NPT 1/2")

#### e: Enclosure material

0 (aluminium)

1 (stainless steel)

### SPECIFIC CONDITIONS OF USE: YES as shown below:

For the applicable ambient temperature range, refer to the equipment description section.

For EPL Db:

- The equipment shall be installed and maintained such that hazards caused by electrostatic discharge are excluded;
- Heat resisting cables and cable glands, suitable for a temperature of at least 20 K higher than the max. ambient temperature shall be used.



# IECEx Certificate of Conformity

Certificate No: IECEx KIWA 18.0014X

Issue No: 0

Date of Issue: 2019-01-09

Page 4 of 4

## EQUIPMENT (continued):

### Electrical Data

Supply and output circuit (terminals +31, -32):

In type of protection intrinsic safety Ex ia IIC, only for connection to a certified intrinsically safe circuit, with the following maximum values:  
UI = 28 V; Ii = 115 mA; Pi = 1.0 W; Ci = 19.2 nF; Li = 0 mH





# IECEx Certificate of Conformity

## INTERNATIONAL ELECTROTECHNICAL COMMISSION IEC Certification System for Explosive Atmospheres

for rules and details of the IECEx Scheme visit [www.iecex.com](http://www.iecex.com)

Certificate No.: **IECEx KIWA 19.0022X** Page 1 of 4 [Certificate history:](#)

Status: **Current** Issue No: 0

Date of Issue: 2019-10-10

Applicant: **SAMSON AKTIENGESELLSCHAFT**  
Weismüllerstraße 3  
60314 Frankfurt  
Germany

Equipment: **Position Transmitter, Type 4749**

Optional accessory:

Type of Protection: **Ex i, Ex d, Ex t**

Marking: Ex ia IIC T6...T4 Gb  
Ex ia IIC T85°C Db  
or  
Ex db IIC T6...T4 Gb  
Ex tb IIC T80°C Db

Approved for issue on behalf of the IECEx  
Certification Body:

**Harry de Wild**

Position:

**Certification Officer**

Signature:  
(for printed version)

\_\_\_\_\_

Date:

\_\_\_\_\_

1. This certificate and schedule may only be reproduced in full.
2. This certificate is not transferable and remains the property of the issuing body.
3. The Status and authenticity of this certificate may be verified by visiting [www.iecex.com](http://www.iecex.com) or use of this QR Code.



Certificate issued by:

**Kiwa Nederland B.V. (Unit Kiwa ExVision)**  
Wilmsdorf 50  
7327 AC Apeldoorn  
P.O. Box 137  
Netherlands





# IECEx Certificate of Conformity

Certificate No.: **IECEx KIWA 19.0022X** Page 2 of 4

Date of issue: **2019-10-10** Issue No: 0

Manufacturer: **SAMSON AKTIENGESELLSCHAFT**  
Weismüllerstraße 3  
60314 Frankfurt  
Germany

Additional  
manufacturing  
locations:

This certificate is issued as verification that a sample(s), representative of production, was assessed and tested and found to comply with the IEC Standard list below and that the manufacturer's quality system, relating to the Ex products covered by this certificate, was assessed and found to comply with the IECEx Quality system requirements. This certificate is granted subject to the conditions as set out in IECEx Scheme Rules, IECEx 02 and Operational Documents as amended

#### STANDARDS :

The equipment and any acceptable variations to it specified in the schedule of this certificate and the identified documents, was found to comply with the following standards

IEC 60079-0:2011 Explosive atmospheres - Part 0: General requirements  
Edition:6.0

IEC 60079-1:2014-06 Explosive atmospheres - Part 1: Equipment protection by flameproof enclosures "d"  
Edition:7.0

IEC 60079-11:2011 Explosive atmospheres - Part 11: Equipment protection by intrinsic safety "i"  
Edition:6.0

IEC 60079-31:2013 Explosive atmospheres - Part 31: Equipment dust ignition protection by enclosure "t"  
Edition:2

This Certificate **does not** indicate compliance with safety and performance requirements other than those expressly included in the Standards listed above.

#### TEST & ASSESSMENT REPORTS:

A sample(s) of the equipment listed has successfully met the examination and test requirements as recorded in:

Test Report:

NL/KIWA/EXTR19.0025/00

Quality Assessment Report:

DE/TUN/QAR06.0011/08



# IECEx Certificate of Conformity

Certificate No.: **IECEx KIWA 19.0022X**

Page 3 of 4

Date of issue: 2019-10-10

Issue No: 0

## EQUIPMENT:

Equipment and systems covered by this Certificate are as follows:

The Position Transmitter Type 4749 is mounted on control valves and converts the lifting or rotating movements of the valve drive into a 4-20 mA current signal.

The position transmitter enclosure is provided with a threaded cover and can be of aluminium or stainless steel.

Type of protection	T-class	Ambient temperature range
Ex ia IIC	T6	-40 °C to +55 °C
	T5	-40 °C to +70 °C
	T4	-40 °C to +80 °C
Ex ia IIIC	T85 °C	-40 °C to +55 °C
Ex db IIC	T6	-55 °C to +65 °C
	T5	-55 °C to +80 °C
	T4	-55 °C to +85 °C
Ex tb IIIC	T80 °C	-55 °C to +65 °C

The Position Transmitter enclosure provides a degree of protection of IP66 in accordance with IEC 60529.

## SPECIFIC CONDITIONS OF USE: YES as shown below:

- For the applicable ambient temperature range, refer to the Equipment section above;
- For Type of protection Ex db: The flameproof joints are not intended to be repaired;
- For Type of protection Ex tb and Ex ia IIIC: The equipment shall be installed and maintained such that hazards caused by electrostatic discharge are excluded;
- For Type of protection Ex db, Ex tb and Ex ia IIIC: Heat resisting cables and cable glands, suitable for a temperature of at least 20 K higher than the max. ambient temperature shall be used.



# IECEX Certificate of Conformity

Certificate No.: **IECEX KIWA 19.0022X**

Page 4 of 4

Date of issue: 2019-10-10

Issue No: 0

## Equipment (continued):

Type designation

4749-abcde

- a: Approvals  
181 (Intrinsically safe / Explosion proof IECEx)
- b: Options  
0 (position transmitter 4 - 20 mA)
- c: Reserved  
X (not safety relevant)
- d: Field wiring entry  
0 (M20x1,5)  
1 (NPT 1/2")
- e: Enclosure material  
0 (aluminium)  
1 (stainless steel)

Electrical Data

Type of protection db or tb: Power supply:  
12-28 Vdc, 4-20 mA.

Type of protection ia:  
Supply and output circuit (terminals +31, -32): in type of protection intrinsic safety Ex ia IIC, only for connection to a certified intrinsically safe circuit, with the following maximum values:  
 $U_i = 28\text{ V}$ ;  $I_i = 115\text{ mA}$ ;  $P_i = 1.0\text{ W}$ ;  $C_i = 19.2\text{ nF}$ ;  $L_i = 0\text{ mH}$



# IECEX Certificate of Conformity

## INTERNATIONAL ELECTROTECHNICAL COMMISSION IEC Certification Scheme for Explosive Atmospheres

for rules and details of the IECEx Scheme visit [www.iecex.com](http://www.iecex.com)

Certificate No.: IECEX KIWA 18.0017X

Issue No: 0

Certificate history:

Issue No. 0 (2018-11-11)

Status: Current

Page 1 of 3

Date of Issue: 2018-11-11

**Applicant:** SAMSON AKTIENGESELLSCHAFT  
Weismüllerstraße 3  
60314 Frankfurt  
Germany

**Equipment:** Position transmitter, type 4749

*Optional accessory:*

**Type of Protection:** Ex d, Ex t

**Marking:**  
Ex db IIC T6...T4 Gb  
Ex tb IIIC T80 °C Db

*Approved for issue on behalf of the IECEx  
Certification Body:*

Pieter van Breugel

*Position:*

Certification Officer

*Signature:  
(for printed version)*

*Date:*

  
11-NOVEMBER-2018

1. This certificate and schedule may only be reproduced in full.
2. This certificate is not transferable and remains the property of the issuing body.
3. The Status and authenticity of this certificate may be verified by visiting the [Official IECEx Website](http://Official IECEx Website).

Certificate issued by:

Kiwa Nederland B.V. (Unit Kiwa ExVision)  
Wilmersdorf 50  
7327 AC Apeldoorn  
P.O. Box 137  
The Netherlands





# IECEX Certificate of Conformity

Certificate No: IECEX KIWA 18.0017X Issue No: 0  
Date of Issue: 2018-11-11 Page 2 of 3  
Manufacturer: SAMSON AKTIENGESELLSCHAFT  
Weismüllerstraße 3  
60314 Frankfurt  
Germany

Additional Manufacturing location(s):

This certificate is issued as verification that a sample(s), representative of production, was assessed and tested and found to comply with the IEC Standard list below and that the manufacturer's quality system, relating to the Ex products covered by this certificate, was assessed and found to comply with the IECEx Quality system requirements. This certificate is granted subject to the conditions as set out in IECEx Scheme Rules, IECEx 02 and Operational Documents as amended.

#### STANDARDS:

The apparatus and any acceptable variations to it specified in the schedule of this certificate and the identified documents, was found to comply with the following standards:

IEC 60079-0 : 2011 Explosive atmospheres - Part 0: General requirements  
Edition:6.0  
IEC 60079-1 : 2014-06 Explosive atmospheres - Part 1: Equipment protection by flameproof enclosures "d"  
Edition:7.0  
IEC 60079-31 : 2013 Explosive atmospheres - Part 31: Equipment dust ignition protection by enclosure "t"  
Edition:2

*This Certificate does not indicate compliance with electrical safety and performance requirements other than those expressly included in the Standards listed above.*

#### TEST & ASSESSMENT REPORTS:

*A sample(s) of the equipment listed has successfully met the examination and test requirements as recorded in*

#### Test Report:

[NL/KIWA/ExTR18.0020/00](#)

#### Quality Assessment Report:

[DE/TUN/QAR06.0011/08](#)



# IECEx Certificate of Conformity

Certificate No: IECEX KIWA 18.0017X

Issue No: 0

Date of Issue: 2018-11-11

Page 3 of 3

## Schedule

### EQUIPMENT:

*Equipment and systems covered by this certificate are as follows:*

The Position Transmitter Type 4749 is mounted on control valves and converts the lifting or rotating movements of the valve drive into a 4-20 mA current signal.

The position transmitter enclosure is provided with a threaded cover and can be of aluminium or stainless steel.

Ambient temperature range for Ex tb: -55 °C to +65 °C  
Ambient temperature range for Ex d: -55 °C to +65 °C for T6  
-55 °C to +80 °C for T5  
-55 °C to +85 °C for T4

The position transmitter enclosure provides a degree of protection of IP66 in accordance with IEC 60529.

### Type designation

#### 4749-abcde

- a: Approvals  
211 (Explosion proof IECEx)
- b: Options  
1 (position transmitter 4 - 20 mA)
- c: Reserved  
X (not safety relevant)
- d: Field wiring entry  
0 (M20x1,5)  
1 (NPT 1/2")
- e: Enclosure material  
0 (aluminium)  
1 (stainless steel)

### SPECIFIC CONDITIONS OF USE: YES as shown below:

- For the applicable ambient temperature range, refer to the Equipment section above;
- The flameproof joints are not intended to be repaired;
- For EPL Db: The equipment shall be installed and maintained such that hazards caused by electrostatic discharge are excluded;
- Heat resisting cables and cable glands, suitable for a temperature of at least 20 K higher than the max. ambient temperature shall be used.





## 16 Annex

### 16.1 After-sales service

Contact our after-sales service for support concerning service or repair work or when malfunctions or defects arise.

You can reach our after-sales service at [aftersalesservice@samsongroup.com](mailto:aftersalesservice@samsongroup.com).

#### **Addresses of SAMSON AG and its subsidiaries**

The addresses of SAMSON AG, its subsidiaries, representatives and service facilities worldwide can be found on our website ([www.samsongroup.com](http://www.samsongroup.com)) or in all SAMSON product catalogs.

#### **Required specifications**

Please submit the following details:

- Order number and position number in the order
- Type, serial number, device version





**EB 4749 EN**



SAMSON AKTIENGESELLSCHAFT  
Weismüllerstraße 3 · 60314 Frankfurt am Main, Germany  
Phone: +49 69 4009-0 · Fax: +49 69 4009-1507  
samson@samsongroup.com · www.samsongroup.com